

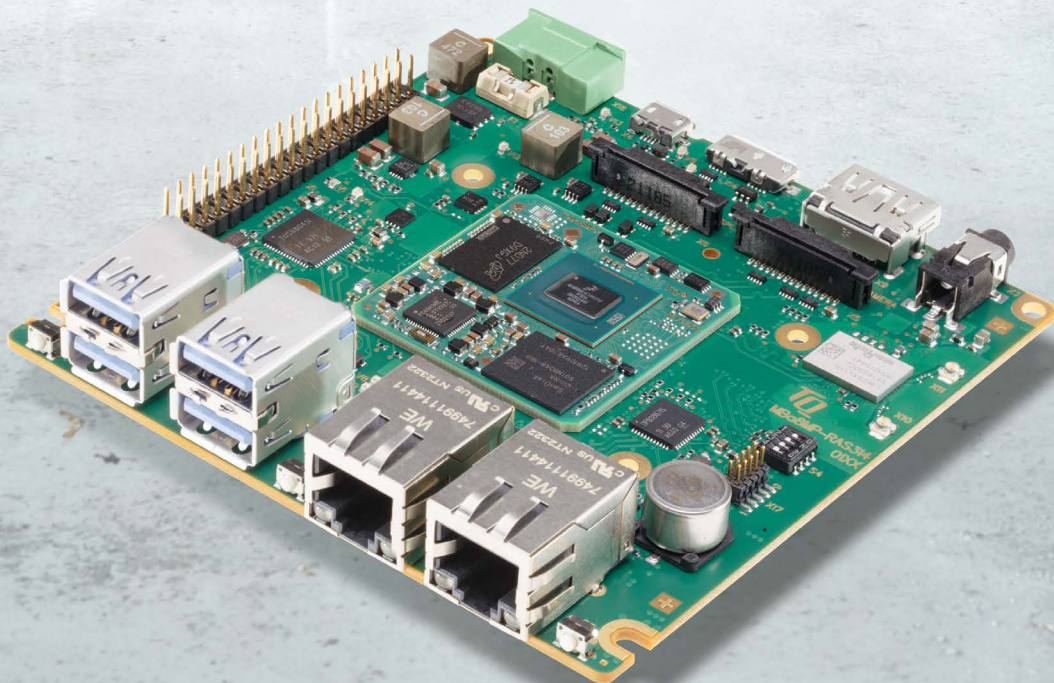

# MBa8MP-RAS314 Preliminary User's Manual

MBa8MP-RAS314 UM 0003  
02.08.2024





## TABLE OF CONTENTS

1.	ABOUT THIS MANUAL.....	6
1.1	Copyright and license expenses .....	6
1.2	Registered trademarks .....	6
1.3	Disclaimer.....	6
1.4	Imprint .....	6
1.5	Tips on safety .....	7
1.6	Symbols and typographic conventions .....	7
1.7	Handling and ESD tips.....	7
1.8	Naming of signals.....	8
1.9	Further applicable documents / presumed knowledge .....	8
2.	BRIEF DESCRIPTION .....	9
2.1	MBa8MP-RAS314 block diagram.....	9
2.2	MBa8MP-RAS314 interfaces, overview .....	10
3.	ELECTRONICS.....	11
3.1	MBa8MP-RAS314 functional groups.....	11
3.1.1	TQMa8MPxL overview .....	11
3.1.2	TQMa8MPxL pinout.....	11
3.1.3	I <sup>2</sup> C devices, address mapping.....	12
3.1.4	RTC backup .....	13
3.1.5	Temperature sensor .....	13
3.1.6	Reset.....	13
3.2	Power supply .....	14
3.2.1	Protective circuitry.....	15
3.2.2	Shared power budgets.....	15
3.3	Communication interfaces.....	16
3.3.1	Ethernet 1000 Base-T (RGMII) .....	16
3.3.2	SD card interface .....	17
3.3.3	USB 3.0 Hub.....	18
3.3.4	USB 3.0 Device / Serial Downloader .....	18
3.3.5	WiFi .....	19
3.3.6	Debug UART .....	19
3.3.7	Camera Interface .....	19
3.3.8	Display Interface.....	20
3.3.9	LVDS .....	20
3.3.10	HDMI .....	22
3.3.11	Audio.....	23
3.3.12	ECSPI.....	23
3.3.13	SPDIF .....	23
3.3.14	GPT.....	23
3.3.15	PWM .....	23
3.3.16	UART.....	23
3.3.17	USDHC .....	24
3.3.18	GPIO header.....	24
3.4	User interfaces and diagnostic.....	25
3.4.1	Boot Mode configuration .....	25
3.4.2	Reset buttons.....	25
3.4.3	Status LEDs.....	25
3.4.4	JTAG® .....	26
4.	SOFTWARE.....	27
5.	MECHANICS.....	27
5.1	MBa8MP-RAS314 dimensions .....	27
5.2	Embedding in the overall system .....	27
5.3	Thermal management.....	27
5.4	Component placement & labeling.....	28
6.	SAFETY REQUIREMENTS AND PROTECTIVE REGULATIONS.....	30
6.1	EMC.....	30
6.2	ESD.....	30
6.3	Operational safety and personal security .....	30



7.	CLIMATIC AND OPERATIONAL CONDITIONS .....	31
7.1	Protection against external effects .....	31
7.2	Reliability and service life.....	31
8.	ENVIRONMENT PROTECTION.....	32
8.1	RoHS .....	32
8.2	WEEE® .....	32
8.3	REACH® .....	32
8.4	EuP .....	32
8.5	Packaging.....	32
8.6	Batteries .....	32
8.7	Other entries .....	32
9.	APPENDIX .....	33
9.1	Acronyms and definitions.....	33
9.2	References.....	35



## TABLE DIRECTORY

Table 1:	Terms and conventions.....	7
Table 2:	Data interfaces .....	10
Table 3:	Diagnostic and user interfaces.....	10
Table 4:	I <sup>2</sup> C devices, address mapping on TQMa8MPxL and MBa8MP-RAS314.....	12
Table 5:	Temperature sensor SE97BTP, D1 .....	13
Table 6:	Reset signals.....	14
Table 7:	Pinout RJ45 Ethernet connector X15, X16.....	16
Table 8:	Pinout microSD card, X2 .....	17
Table 9:	Pinout Camera Interface, X5 .....	20
Table 10:	Pinout Display Interface, X6 .....	20
Table 11:	Pinout LVDS data, X7.....	21
Table 12:	Pinout LVDS control, X8 .....	21
Table 13:	Pinout HDMI connector, X9.....	22
Table 14:	Pinout audio connector X3 .....	23
Table 15:	SPDIF signal usage .....	23
Table 16:	Pinout GPIO header, X1 .....	24
Table 17:	Boot Source options TQMa8MPxL .....	25
Table 18:	Status LEDs.....	25
Table 19:	Pinout JTAG <sup>®</sup> pin header, X17.....	26
Table 20:	Labels on MBa8MP-RAS314 .....	29
Table 21:	Climatic and operational conditions MBa8MP-RAS314 .....	31
Table 22:	Acronyms.....	33
Table 23:	Further applicable documents.....	35



## FIGURE DIRECTORY

Figure 1:	Block diagram MBa8MP-RAS314 .....	9
Figure 2:	Block diagram TQMa8MPxL .....	11
Figure 3:	Block diagram I <sup>2</sup> C bus .....	12
Figure 4:	Block diagram MBa8MP-RAS314 Reset structure.....	13
Figure 5:	Block diagram power supply MBa8MP-RAS314 .....	14
Figure 6:	MBa8MP-RAS314 protective circuit.....	15
Figure 7:	Block diagram Ethernet 1000 Base-T .....	16
Figure 8:	Block diagram SD card interface, MBa8MP-RAS314.....	17
Figure 9:	Block diagram USB 3.0 Hub.....	18
Figure 10:	Block diagram WiFi .....	19
Figure 11:	Block diagram UARTs.....	19
Figure 12:	Block diagram MIPI CSI .....	19
Figure 13:	Block diagram LVDS .....	21
Figure 14:	Block diagram HDMI.....	22
Figure 15:	Block diagram audio interface .....	23
Figure 16:	Block diagram JTAG.....	26
Figure 17:	Dimensions MBa8MP-RAS314.....	27
Figure 18:	MBa8MP-RAS314 component placement top .....	28
Figure 19:	MBa8MP-RAS314 component placement bottom .....	29



## REVISION HISTORY

Rev.	Date	Name	Pos.	Modification
0001	11.10.2023	Kreuzer		First edition
0002	04.03.2024	Kreuzer	Figure 17	added
0003	02.08.2024	Kreuzer	3.2 6.4, 6.5, 6.6, 6.7, 8.5	Range corrected added



## 1. ABOUT THIS MANUAL

### 1.1 Copyright and license expenses

Copyright protected © 2024 by TQ-Systems GmbH.

This Preliminary User's Manual may not be copied, reproduced, translated, changed or distributed, completely or partially in electronic, machine readable, or in any other form without the written consent of TQ-Systems GmbH.

The drivers and utilities for the components used as well as the BIOS are subject to the copyrights of the respective manufacturers. The licence conditions of the respective manufacturer are to be adhered to.

Bootloader-licence expenses are paid by TQ-Systems GmbH and are included in the price.

Licence expenses for the operating system and applications are not taken into consideration and must be calculated / declared separately.

### 1.2 Registered trademarks

TQ-Systems GmbH aims to adhere to copyrights of all graphics and texts used in all publications, and strives to use original or license-free graphics and texts.

All brand names and trademarks mentioned in this Preliminary User's Manual, including those protected by a third party, unless specified otherwise in writing, are subjected to the specifications of the current copyright laws and the proprietary laws of the present registered proprietor without any limitation. One should conclude that brand and trademarks are rightly protected by a third party.

### 1.3 Disclaimer

TQ-Systems GmbH does not guarantee that the information in this Preliminary User's Manual is up-to-date, correct, complete or of good quality. Nor does TQ-Systems GmbH assume guarantee for further usage of the information. Liability claims against TQ-Systems GmbH, referring to material or non-material related damages caused, due to usage or non-usage of the information given in this Preliminary User's Manual, or due to usage of erroneous or incomplete information, are exempted, as long as there is no proven intentional or negligent fault of TQ-Systems GmbH.

TQ-Systems GmbH explicitly reserves the rights to change or add to the contents of this Preliminary User's Manual or parts of it without special notification.

#### **Important Notice:**

Before using the MBa8MP-RAS314 or parts of the MBa8MP-RAS314 schematics, you must evaluate it and determine if it is suitable for your intended application. You assume all risks and liability associated with such use. TQ-Systems GmbH makes no other warranties including, but not limited to, any implied warranty of merchantability or fitness for a particular purpose. Except where prohibited by law, TQ-Systems GmbH will not be liable for any indirect, special, incidental or consequential loss or damage arising from the usage of the MBa8MP-RAS314 or schematics used, regardless of the legal theory asserted.

### 1.4 Imprint

TQ-Systems GmbH  
Gut Delling, Mühlstraße 2  
**D-82229 Seefeld**

Tel: +49 8153 9308-0

Fax: +49 8153 9308-4223

E-Mail: [Info@TQ-Group.com](mailto:Info@TQ-Group.com)





Web: [TQ-Group](http://TQ-Group)

## 1.5 Tips on safety

Improper or incorrect handling of the product can substantially reduce its life span.

## 1.6 Symbols and typographic conventions

Table 1: Terms and conventions

Symbol	Meaning
	This symbol represents the handling of electrostatic-sensitive modules and / or components. These components are often damaged / destroyed by the transmission of a voltage higher than about 50 V. A human body usually only experiences electrostatic discharges above approximately 3,000 V.
	This symbol indicates the possible use of voltages higher than 24 V. Please note the relevant statutory regulations in this regard. Non-compliance with these regulations can lead to serious damage to your health and cause damage / destruction of the component.
	This symbol indicates a possible source of danger. Acting against the procedure described can lead to possible damage to your health and / or cause damage / destruction of the material used.
	This symbol represents important details or aspects for working with TQ-products.
<b>Command</b>	A font with fixed-width is used to denote commands, file names, or menu items.

## 1.7 Handling and ESD tips

General handling of your TQ-products

	<p>The TQ-product may only be used and serviced by certified personnel who have taken note of the information, the safety regulations in this document and all related rules and regulations.</p> <p>A general rule is not to touch the TQ-product during operation. This is especially important when switching on, changing jumper settings or connecting other devices without ensuring beforehand that the power supply of the system has been switched off.</p> <p>Violation of this guideline may result in damage / destruction of the MBa8MP-RAS314 and be dangerous to your health.</p> <p>Improper handling of your TQ-product would render the guarantee invalid.</p>
---	--

Proper ESD handling

	<p>The electronic components of your TQ-product are sensitive to electrostatic discharge (ESD).</p> <p>Always wear antistatic clothing, use ESD-safe tools, packing materials etc., and operate your TQ-product in an ESD-safe environment. Especially when you switch modules on, change jumper settings, or connect other devices.</p>
---	--





## 1.8 Naming of signals

A hash mark (#) at the end of the signal name indicates a low-active signal.

Example: RESET#

If a signal can switch between two functions and if this is noted in the name of the signal, the low-active function is marked with a hash mark and shown at the end.

Example: C / D#

If a signal has multiple functions, the individual functions are separated by slashes when they are important for the wiring. The identification of the individual functions follows the above conventions.

Example: WE2# / OE#

## 1.9 Further applicable documents / presumed knowledge

- **Specifications and manual of the modules used:**  
These documents describe the service, functionality and special characteristics of the module used (incl. BIOS).
- **Specifications of the components used:**  
The manufacturer's specifications of the components used, for example CompactFlash cards, are to be taken note of. They contain, if applicable, additional information that must be taken note of for safe and reliable operation. These documents are stored at TQ-Systems GmbH.
- **Chip errata:**  
It is the user's responsibility to make sure all errata published by the manufacturer of each component are taken note of. The manufacturer's advice should be followed.
- **Software behaviour:**  
No warranty can be given, nor responsibility taken for any unexpected software behaviour due to deficient components.
- **General expertise:**  
Expertise in electrical engineering / computer engineering is required for the installation and the use of the device.

The following documents are required for full comprehension of this Preliminary User's Manual:

- MBa8MP-RAS314 schematics
- TQMa8MPxL Preliminary User's Manual
- i.MX 8M Plus Data Sheet
- i.MX 8M Plus Reference Manual
- U-Boot documentation: [www.denx.de/wiki/U-Boot/Documentation](http://www.denx.de/wiki/U-Boot/Documentation)
- Yocto documentation: [www.yoctoproject.org/docs/](http://www.yoctoproject.org/docs/)
- TQ-Support Wiki: <https://support.tq-group.com/en/arm/tqma8mp-ras314>

## 2. BRIEF DESCRIPTION

This Preliminary User's Manual describes the hardware of the MBa8MP-RAS314 as of revision 01xx.

The MBa8MP-RAS314 is designed as a carrier board for the TQMa8MPxL. The TQMa8MPxL is directly soldered on the MBa8MP-RAS314.

Core of the MBa8MP-RAS314 is the TQMa8MPxL with an NXP i.MX 8M Plus CPU based on a Dual or Quad Cortex<sup>®</sup>-A53.

The TQMa8MPxL connects all peripheral components. In addition to the standard communication interfaces such as USB, Ethernet, SD card, etc., most other available TQMa8MPxL signals are routed on 100 mil pin headers on the MBa8MP-RAS314. CPU features and interface can be evaluated, software development for a TQMa8MPxL-based project can start immediately. Currently four i.MX 8M Plus derivatives are supported:

- 1) i.MX 8M Plus Dual (Dual Cortex<sup>®</sup>-A53)
- 2) i.MX 8M Plus Quad 4 Lite (Quad Cortex<sup>®</sup>-A53)
- 3) i.MX 8M Plus Quad 6 Video (Quad Cortex<sup>®</sup>-A53)
- 4) i.MX 8M Plus Quad 8 ML/AI (Quad Cortex<sup>®</sup>-A53)

### 2.1 MBa8MP-RAS314 block diagram

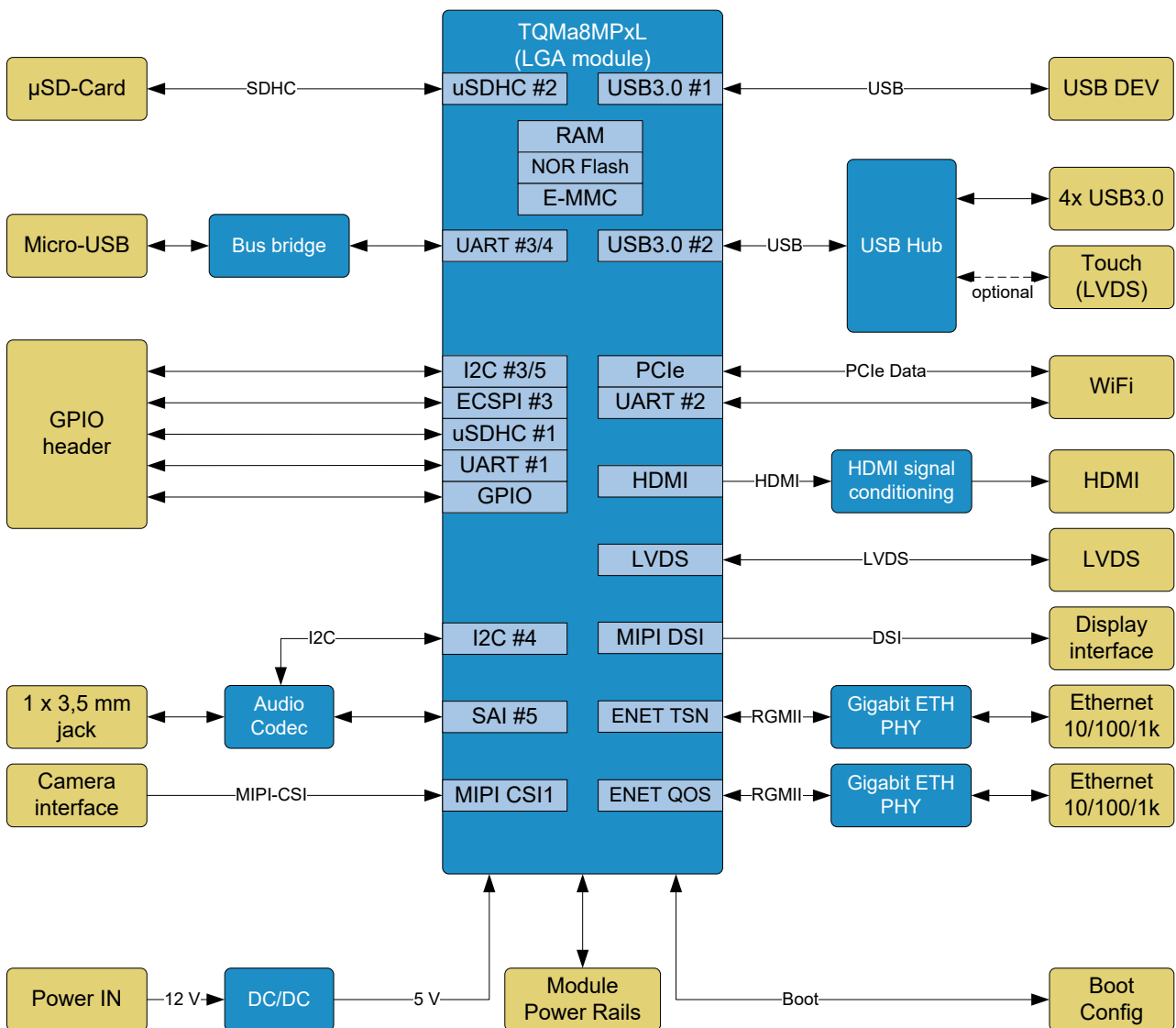

Figure 1: Block diagram MBa8MP-RAS314

## 2.2 MBa8MP-RAS314 interfaces, overview

The following interfaces/functions and user interfaces are available on the MBa8MP-RAS314:

Table 2: Data interfaces

Interface	Connector	Type	Remark
Audio	X3	1 × 3.5 mm jack	MIC (mono), headphone (stereo)
Camera interface	X5	1-1734248-5, TE Connectivity	–
Display Interface	X6	1-1734248-5, TE Connectivity	–
Eth. 1000 Base-T	X15, X16	RJ45	Gigabit PHY DP83867 and socket with integrated transformers
GPIO	X1	SL-22-124-40-G, 2,54 mm	Connected to IO bank (GPIO)
HDMI	X9	HDMI	–
JTAG	X17	10-pin, 50 mil pin header	JTAG
LVDS CMD	X8	14-pin, DF19G	ZIF connector
LVDS Data	X7	20-pin, DF19G	ZIF connector
SD card	X2	Micro-SD	USDHC2, optional boot source
USB 3.0	X12, X13	Stacked Type A	–
USB Debug	X4	Micro USB AB	UART3, UART4
USB 3.0 DEV	X14	Micro USB Type B	USB 3.0 Device or Serial Downloader
WiFi	X10, X11	U.FL-R-SMT-1(10)	–

The MBa8MP-RAS314 provides the following diagnostic and user interfaces:

Table 3: Diagnostic and user interfaces

Interface	Reference	Component	Remark
Status LEDs		1 × Red LED	Reset
		5 × Green LED	Voltages on MBa8MP-RAS314
		1 × Green LED	General purpose LED
		1 × Orange LED	General purpose LED
		1 × Green LED	SD-Card
		1 × Green LED	Debug-USB
		4 × Green LED	USB V_VBUS30_H1...H4
		4 × Green LED	Ethernet link / activity
Power / Reset	S1		Reset
	S2	3 × Pushbutton	PMIC reset
	S3		CPU-ON/OFF
Boot-Mode	S4	1 × 4-fold DIP switch	Boot Device selection

### 3. ELECTRONICS

#### 3.1 MBa8MP-RAS314 functional groups

The following chapters describe the interfaces of the MBa8MP-RAS314 in connection with a TQMa8MPxL.

##### 3.1.1 TQMa8MPxL overview

The MBa8MP-RAS314 provides all power supplies and configurations required for the operation of the TQMa8MPxL. The TQMa8MPxL is the central system on the MBa8MP-RAS314. It provides LPDDR4 SDRAM, eMMC, NOR flash, RTC, an EEPROM, power supply and power management functionality. All TQMa8MPxL internal voltages are derived from the 5 V supply voltage. All functionally relevant pins of the i.MX 8M Plus are routed to the TQMa8MPxL connectors or LGA pads. This enables to use the TQMa8MPxL with all the freedom that comes with a customer-specific design-in solution. Further information can be found in the TQMa8MPxL User's Manual.

On the MBa8MP-RAS314 the standard interfaces like USB, Ethernet, etc., provided by the TQMa8MPxL are routed to industry standard connectors. Most other relevant signals and buses provided by the TQMa8MPxL are routed to 100 mil pin headers on the MBa8MP-RAS314.

The boot behaviour of the TQMa8MPxL can be controlled. The boot mode configuration is set with a DIP switch on the MBa8MP-RAS314.

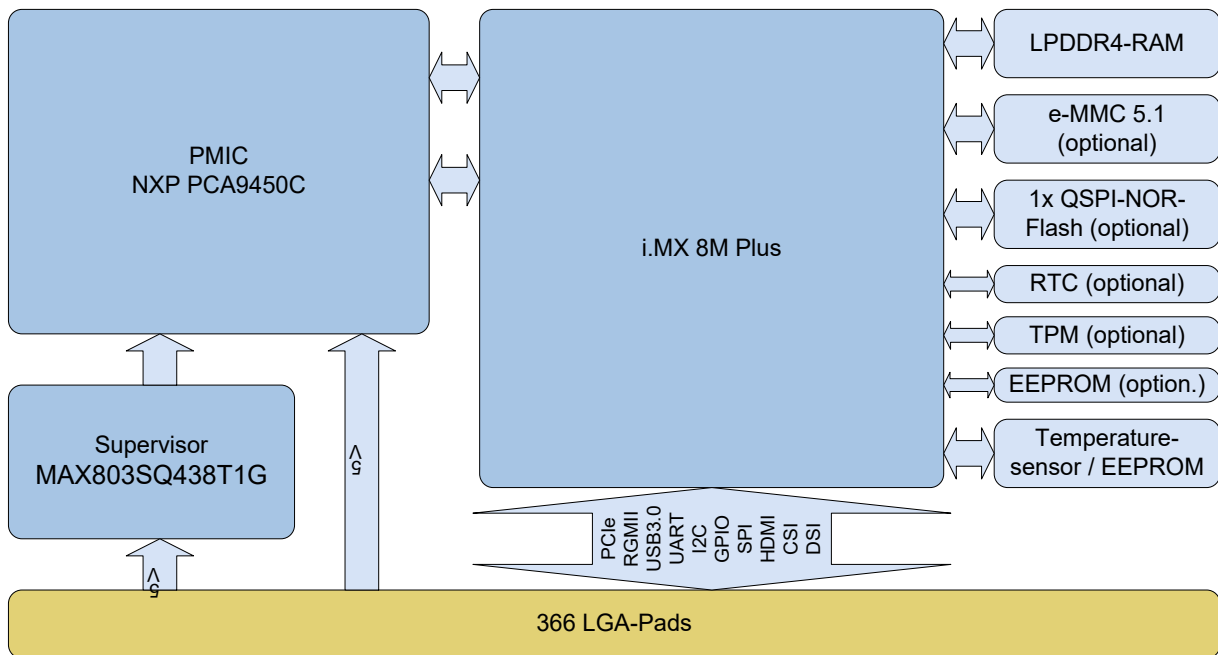



Figure 2: Block diagram TQMa8MPxL

##### 3.1.2 TQMa8MPxL pinout

The most relevant TQMa8MPxL signals that are not already used are routed out to a header on the MBa8MP-RAS314.

Note: Available interfaces	
	<p>Depending on the TQMa8MPxL derivative, not all interfaces are available. More information about available interfaces can be found in the TQMa8MPxL User's Manual and pinout tables.</p>

### 3.1.3 I<sup>2</sup>C devices, address mapping

The TQMa8MPxL provides five I<sup>2</sup>C buses. Of these, only I2C3 and I2C5 are provided on a pin header. All other buses are used by different components on the module or the mainboard.

The following block diagram shows the I<sup>2</sup>C bus structure.

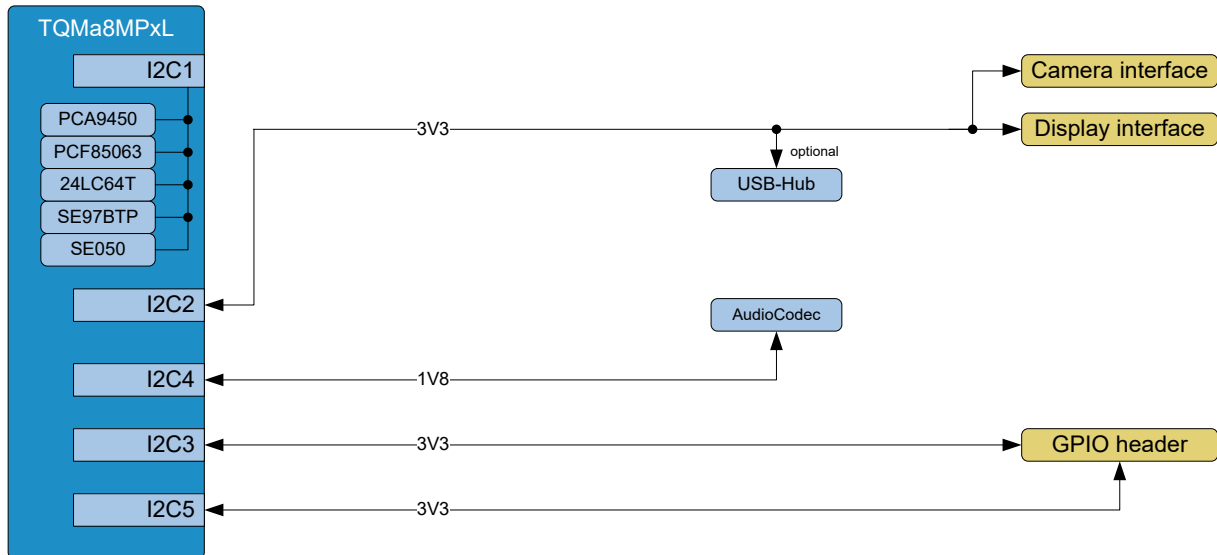

Figure 3: Block diagram I<sup>2</sup>C bus

The following table shows the addresses used on the TQMa8MPxL and the MBa8MP-RAS314.

Table 4: I<sup>2</sup>C devices, address mapping on TQMa8MPxL and MBa8MP-RAS314

Location	Device	Function	Bus	7-bit address	Remark
TQMa8MPxL	PCA9450	System Controller	I2C1	0x25 / 010 0101b	Should not be altered
	PCF85063	RTC		0x51 / 101 0001b	Optional
	24LC64T	EEPROM		0x57 / 101 0111b	Optional
	SE97BTP	Temperature sensor		0x1B / 001 1011b	–
		EEPROM		0x33 / 011 0011b	R/W access in Protected Mode
				0x53 / 101 0011b	R/W access in Normal Mode
	SE050	Trust Secure Element		0x48 / 100 1000b	Optional
MBa8MP-RAS314	TLV320AIC3204	Audio Codec	I2C4	0x18 / 001 1000b	N1
	TUSB8041	USB 3.0 hub	I2C2	0x44 / 100 0100b	D10
	X5	Camera interface		(Device dependent)	–
	X6	Display interface	(Device dependent)	–	
	X1	GPIO header	I2C3	(Device dependent)	–
I2C5			(Device dependent)	–	

### 3.1.4 RTC backup

In case of power failure or power down, a Goldcap capacitor on the MBa8MP-RAS314 supplies the RTC on the TQMa8MPxL. The TQMa8MPxL features an i.MX 8M Plus-internal RTC or a discrete RTC PCF85063A. The RTC is supplied in either way.

### 3.1.5 Temperature sensor

The SE97BTP sensor is used to monitor the temperature of the TQMa8MPxL. The sensor is connected to I2C1; see Table 4.

Table 5: Temperature sensor SE97BTP, D1

Manufacturer	Device	Resolution	Accuracy	Temperature range
NXP	SE97BTP	11 bits	Max. $\pm 1$ °C	+75 °C to +95 °C
			Max. $\pm 2$ °C	+40 °C to +125 °C
			Max. $\pm 3$ °C	-40 °C to +125 °C

### 3.1.6 Reset

The RESET\_OUT# signal of the TQMa8MPxL is available on the MBa8MP-RAS314. A red LED (V1) on the MBa8MP-RAS314 indicates a reset condition; see Table 26.

On the MBa8MP-RAS314 a partial reset of the TQMa8MPxL is possible, e.g. with signal RESET\_IN#.

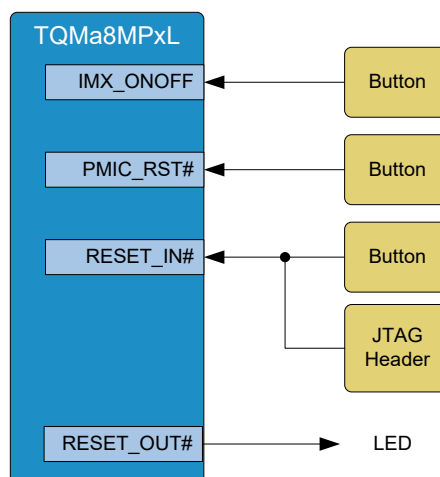

Figure 4: Block diagram MBa8MP-RAS314 Reset structure

Attention: RESET_OUT# / PMIC_RST#	
	<p>Attention: The signal RESET_OUT# is designed as a reset triggering signal. To feed a reset signal into the system, it is mandatory to use the signal PMIC_RST#.</p>

Table 6: Reset signals

Signal	Dir.	Source	Default	Remark
RESET_OUT#	O	TQMa8MPxL	High	<ul style="list-style-type: none"> <li>Requires pull-up on carrier board (max. 6.5 V)</li> </ul>
IMX_ONOFF	I	MBa8MP-RAS314	High	<ul style="list-style-type: none"> <li>ON/OFF function; see i.MX 8M Plus data sheet (1)</li> <li>No pull-up on carrier board required; low-active</li> <li>Connect 5 s to GND to activate</li> </ul>
PMIC_RST#	I	MBa8MP-RAS314	High	<ul style="list-style-type: none"> <li>No pull-up on carrier board required; low-active</li> <li>Programmable PMIC response (warm reset, cold reset)</li> </ul>
RESET_IN#	I	MBa8MP-RAS314	High	<ul style="list-style-type: none"> <li>Activates POR_B of the i.MX 8M Plus; low-active</li> <li>Connect to GND to activate</li> </ul>
PMIC_WDOG_IN#	I	MBa8MP-RAS314	High	<ul style="list-style-type: none"> <li>No pull-up on carrier board required; low-active</li> <li>Disabled by default on PMIC side</li> <li>Programmable PMIC response (warm reset, cold reset)</li> </ul>
PMIC_WDOG_OUT#	O	TQMa8MPxL	-	<ul style="list-style-type: none"> <li>Multiplexed to GPIO1_IO02 pin of i.MX 8M Plus</li> <li>Connected to PMIC_WDOG_IN# via 0 Ω bridge</li> </ul>

### 3.2 Power supply

At X18, the MBa8MP-RAS314 has to be supplied with 12 V +/-10 % (10.8 V to 13.2 V). All other voltages required on the MBa8MP-RAS314 are derived from this supply voltage. The MBa8MP-RAS314 has a theoretical maximum power consumption of approx. 42 W at its 12 V supply connection. This corresponds to a maximum typical current of 3.5 A at 12 V. The power supply unit used must be selected accordingly. In most applications, however, the power consumption will be significantly lower and the MBa8MP-RAS314 including TQMa8MPxL consumes approx. 5 W to 6 W when the i.MX 8M Plus operates at 100 % load. Most of the theoretically possible power consumption results from the standard-compliant supply of the USB and LVDS interfaces, as well as from the power available at the pin headers. It must be ensured that the permissible limit values of the input circuitry are not exceeded.

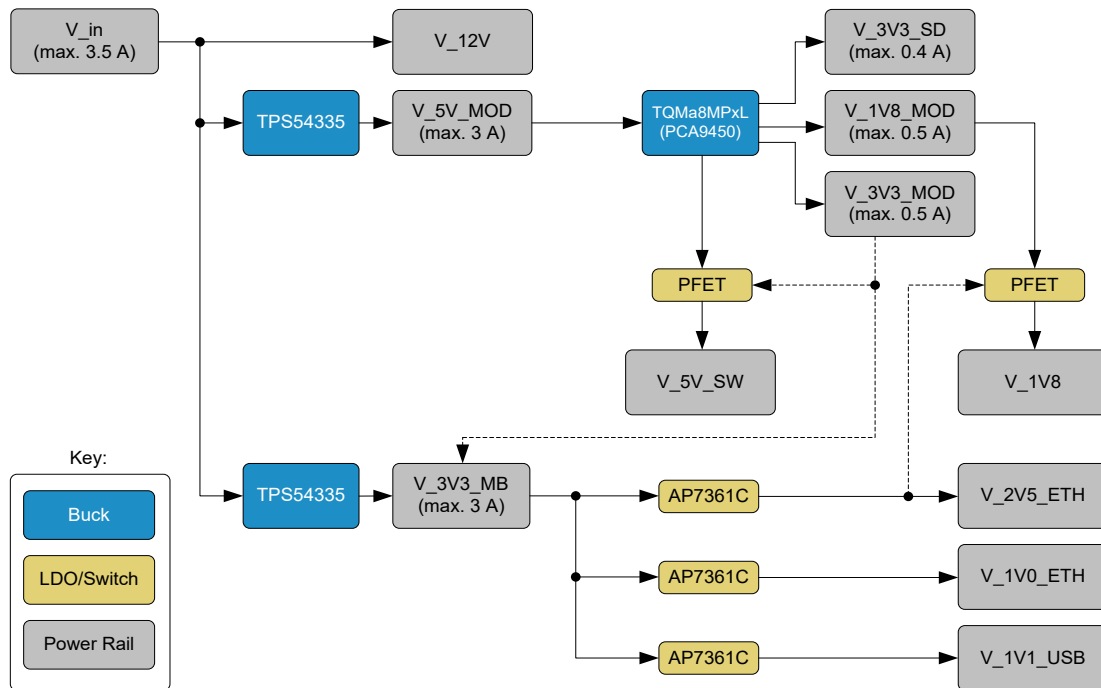

Figure 5: Block diagram power supply MBa8MP-RAS314

### 3.2.1 Protective circuitry

The protective circuit (see Figure 8) features the following characteristics:

- Overcurrent protection by fuse 7 A, Slow Blow
- Overvoltage protection
- PI filter
- Reverse polarity protection
- Capacitors for voltage smoothing

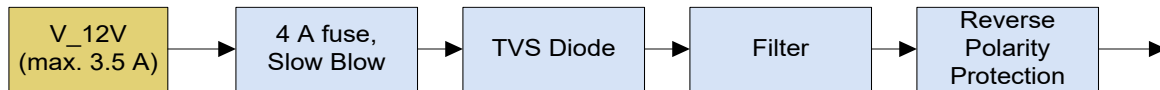

Figure 6: MBa8MP-RAS314 protective circuit

### 3.2.2 Shared power budgets

Ensure maximum listed power budget for IO interfaces is not exceeded.  
Observe maximum current rating on the individual connectors.

Voltage Rail	Power Budget (mA)	Available on connector
V_3V3_MB	1500	X5 (Camera), X6 (Display), X7 & X8 (LVDS), X1 (GPIO Header)
V_5V_SW	1000	X7 & X8 (LVDS), X9 (HDMI), X1 (GPIO Header)

#### Attention: Maximum current of 3.3 V and 5 V rails



The currents load of the 3.3 V and 5 V rails add up to the current consumption of the MBa8MP-RAS314. The additional power required must be provided by the power supply of the MBa8MP-RAS314. The maximum load of the fuse must be observed.



### 3.3 Communication interfaces

#### 3.3.1 Ethernet 1000 Base-T (RGMII)

The i.MX 8M Plus CPU has two independent RGMII interfaces. On the MBa8MP-RAS314 both interfaces are used to provide two Gigabit Ethernet ports by means of two DP83867 Ethernet PHYs.

The PHY has boot straps to start with adjustable default values. Some boot straps can be customized with placement options. More information is available in the latest MBa8MP-RAS314 schematic.

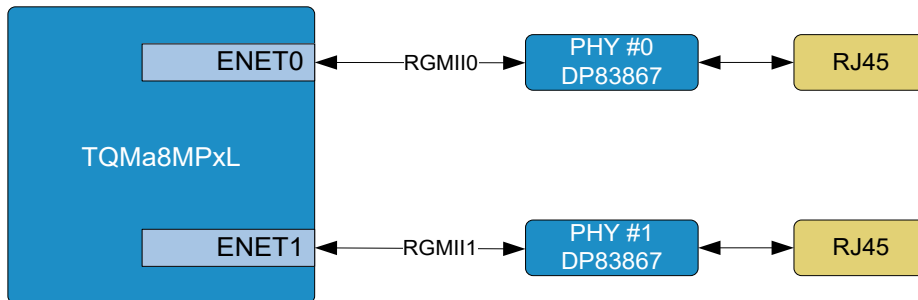

Figure 7: Block diagram Ethernet 1000 Base-T

Table 7: Pinout RJ45 Ethernet connector X15, X16

X15			X16			Remark
Pin	Pin name	Signal	Pin	Pin name	Signal	
1	GND	GND	1	GND	GND	-
2	TD0+	ENET0_A+	2	TD0+	ENET1_A+	-
3	TD0-	ENET0_A-	3	TD0-	ENET1_A-	-
6	TD1+	ENET0_B+	6	TD1+	ENET1_B+	-
4	TD1-	ENET0_B-	4	TD1-	ENET1_B-	-
5	TD2+	ENET0_C+	5	TD2+	ENET1_C+	-
7	TD2-	ENET0_C-	7	TD2-	ENET1_C-	-
8	TD3+	ENET0_D+	8	TD3+	ENET1_D+	-
9	TD4-	ENET0_D-	9	TD4-	ENET1_D-	-
10	CHS.GND	GND	10	CHS.GND	GND	-
11	GREEN_ANODE	V_3V3_MB	11	GREEN_ANODE	V_3V3_MB	120 Ω in series
12	GREEN_CATHODE	ENET0_LED_0	12	GREEN_CATHODE	ENET1_LED_0	Switched by transistor
13	GREEN_ANODE	V_3V3_MB	13	GREEN_ANODE	V_3V3_MB	120 Ω in series
14	GREEN_CATHODE	ENET0_LED_2	14	GREEN_CATHODE	ENET1_LED_2	Switched by transistor

### 3.3.2 SD card interface

The MBa8MP-RAS314 offers a microSD card slot that can also be used as boot source. All signals are directly connected to the USDHC2 interface of the i.MX 8M Plus.

The TQMa8MPxL voltage V\_3V3\_SD supplies the microSD card slot. This voltage is controlled by SD\_RESET#, therefore the microSD card is automatically reset in case of a Reset. An external switch is not required. Signal USDHC2\_CD# has a pull-up on the MBa8MP-RAS314. All data lines are ESD protected.

Standard, High and Extended capacity card types are supported. Default Speed, High Speed, and SD UHS-1 Speed Mode SDR104 with theoretically max.104 MB/s are supported. UHS-1 Speed Modes SDR12, SDR25, SDR50 and DDR50 are theoretically supported but not verified.

The TQMa8MPxL sets USDHC2 to 1.8 V or 3.3 V automatically, depending on the transfer mode. The corresponding driver handles the changeover; it does not have to be done explicitly.

USDHC2\_WP is not used and is terminated accordingly.

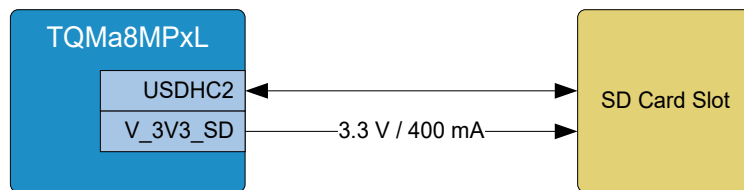

Figure 8: Block diagram SD card interface, MBa8MP-RAS314

Table 8: Pinout microSD card, X2

Pin	Pin name	Signal	Remark
1	DAT2	USDHC2_DATA2	10 kΩ PU
2	DAT3	USDHC2_DATA3	10 kΩ PU
3	CMD	USDHC2_CMD	10 kΩ PU
4	VDD	V_3V3_SD	Supply from TQMa8MPxL
5	CLK	USDHC2_CLK	–
6	GND	GND	–
7	DAT0	USDHC2_DATA0	10 kΩ PU
8	DAT1	USDHC2_DATA1	10 kΩ PU
SW1	CD#	GND	–
SW2	CD#	USDHC2_CD#	10 kΩ PU
M1...4	Shield	GND	–

### 3.3.3 USB 3.0 Hub

A USB 3.0 hub TUSB8041 is connected to the USB2 interface on the MBa8MP-RAS314, which provides four USB 3.0 / 2.0 host interfaces.

USB Host 1 & 2 of the TUSB8041 are connected to a Dual USB 3.0 Type A socket (X12) on the MBa8MP-RAS314. USB Host 3 & 4 are routed to the connector X13.

USB Host 4 can be routed to the LVDS-CMD connector X8 on the MBa8MP-RAS314 by changing the resistor placement R152/153 (STD) and R156/157 (OPT).

The USB hub is programmed via bootstrapping or as a placement option via I<sup>2</sup>C. Further information can be found in the TUSB8041 data sheet and the MBa8MP-RAS314 schematics.

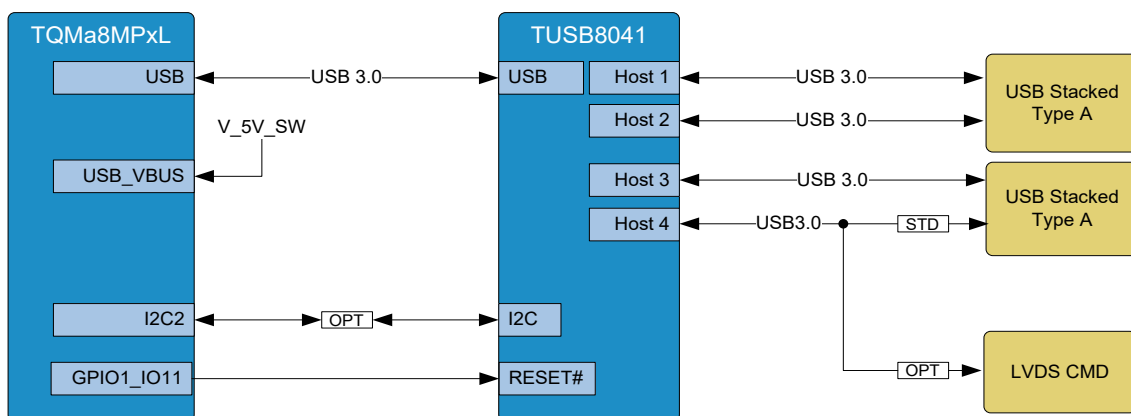

Figure 9: Block diagram USB 3.0 Hub

The USB connectors are supplied with 5 V via power switches. The current is monitored and can be switched off in case of an overload and/or overheating.

The USB 3.0 port of the TQMa8MPxL provides a theoretical data rate of 5 Gbit/s. This is divided among the connected ports on the MBa8MP-RAS314. Depending on the software and hardware used, the effective read and write rates of the ports may vary.

### 3.3.4 USB 3.0 Device / Serial Downloader

The USB1 interface of the TQMa8MPxL is configured as USB 3.0 Device and routed to USB Micro-B connector X14 on the MBa8MP-RAS314. This interface can be used for the Serial Download Mode of the TQMa8MPxL. It can be used as a normal USB 3.0 or USB 2.0 device interface.

The USB1 interface of the TQMa8MPxL provides a theoretical data rate of 5 Gbit/s. Depending on the software and hardware used, the effective read and write rates of the ports may vary.

### 3.3.5 WiFi

A WiFi module (LBEE5XV1YM from Murata) is available on the MBa8MP-RAS314. It supports IEEE 802.11 a/b/g/n/ac and offers a dual-band RF interface (2.4 / 5 GHz).

The LBEE5XV1YM is connected to the MBa8MP-RAS314 via PCIe (for WiFi) and UART (for a wireless function). The theoretically achievable maximum data rate of the LBEE5XV1YM is 866 Mbit/s.

The antennas have to be connected separately to the U.FL-R-SMT-1(10) sockets (X10, X11) and are not part of the MBa8MP-RAS314.

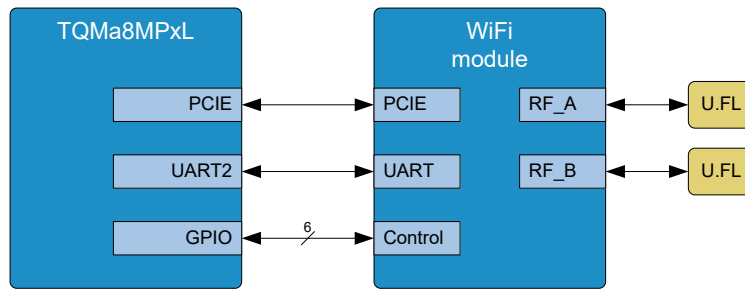

Figure 10: Block diagram WiFi

### 3.3.6 Debug UART

For debug functionalities UART3 and UART4 are provided as virtual COM ports via USB.

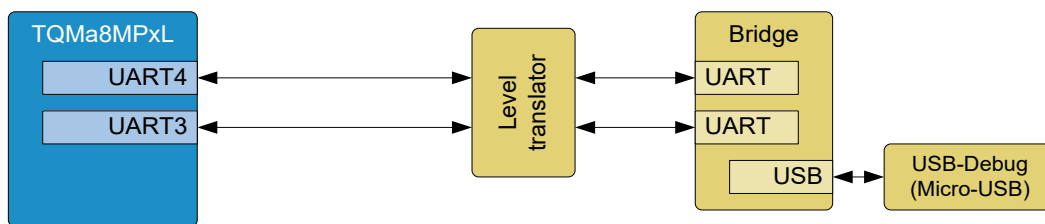

Figure 11: Block diagram UARTs

The CP2105-bridge is bus-powered so that the COM port on the PC side is maintained even if the mainboard power supply is interrupted.

### 3.3.7 Camera Interface

A camera interface provided by the TQMa8MPxL is routed to connector X5 (Type 1-1734248-5) on the MBa8MP-RAS314.

The GPIO signals of the interface are connected to the GPIO2 signals (GPIO2\_6/\_7) of the TQMa8MPxL.

The I<sup>2</sup>C bus operate at 1.8 V and is connected to I2C2 on the MBa8MP-RAS314.

Common mode chokes have to be located at the source on camera module. "Camera Module v2" and "HQ Camera" from raspberrypi.org have common mode chokes onboard.

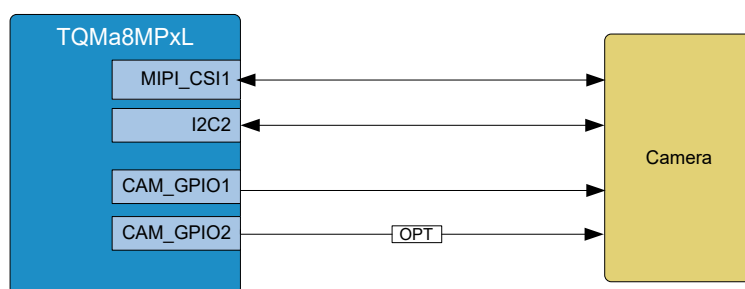

Figure 12: Block diagram MIPI CSI

Table 9: Pinout Camera Interface, X5

Pin	Signal	Remark
1	GND	–
2	MIPI_CSI1_DATA0_N	–
3	MIPI_CSI1_DATA0_P	–
4	GND	–
5	MIPI_CSI1_DATA1_N	–
6	MIPI_CSI1_DATA1_P	–
7	GND	–
8	MIPI_CSI1_CLK_N	–
9	MIPI_CSI1_CLK_P	–
10	GND	–
11	CAM_GPIO1	Enable
12	CAM_GPIO2	LED (optional)
13	I2C2_SCL	–
14	I2C2_SDA	–
15	V_3V3_MB	max. 1.0 A

### 3.3.8 Display Interface

A display interface provided by the TQMa8MPxL is routed to connector X6 (Type 1-1734248-5) on the MBa8MP-RAS314.

Table 10: Pinout Display Interface, X6

Pin	Signal	Remark
1	GND	–
2	MIPI_DSI1_DATA1_N_L	–
3	MIPI_DSI1_DATA1_P_L	–
4	GND	–
5	MIPI_DSI1_CLK_N_L	–
6	MIPI_DSI1_CLK_P_L	–
7	GND	–
8	MIPI_DSI1_DATA0_N_L	–
9	MIPI_DSI1_DATA0_P_L	–
10	GND	–
11	I2C2_SCL	–
12	I2C2_SDA	–
13	GND	–
14	V_3V3_MB	max. 1.0 A
15		

### 3.3.9 LVDS

The i.MX 8M Plus offers an LVDS controller with a dual LVDS interface. Each of the interfaces uses four differential lanes. On the MBa8MP-RAS314 there is one interface for connecting Single LVDS. In addition, two GPIO (BLT\_EN, RESET#), a PWR\_EN and a PWM signal are provided. GPIO1\_IO03, GPIO1\_IO01, GPIO1\_IO07 and GPIO1\_IO09 are used for these four 3.3 V signals. Both LVDS interfaces - Data and CMD – use DF19 connectors.

The USB signals of the CMD connector are optional connected to port 4 of the USB 3.0 hub (see 3.3.3).

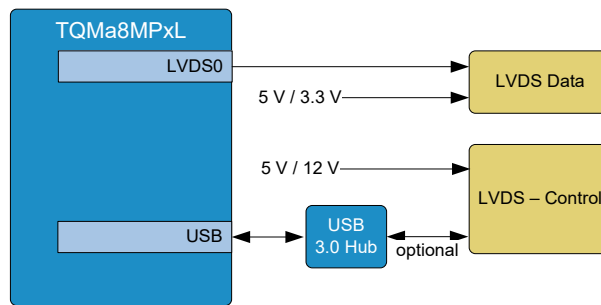

Figure 13: Block diagram LVDS

Table 11: Pinout LVDS data, X7

Pin	Signal	Remark
1	LVDS0_D0_N	-
2	LVDS0_D0_P	-
3	LVDS0_D1_N	-
4	LVDS0_D1_P	-
5	LVDS0_D2_N	-
6	LVDS0_D2_P	-
7	GND	-
8	LVDS0_CLK_N	-
9	LVDS0_CLK_P	-
10	LVDS0_D3_N	-
11	LVDS0_D3_P	-
12	GND	-
13		
14		
15	V_5V_LVDS0	max. 1.0 A
16		
17		
18	V_3V3_LVDS0	max. 1.0 A
19		
20		

Table 12: Pinout LVDS control, X8

Pin	Signal	Remark
1	V_12V	max. 1.0 A
2		
3	GND	-
4	V_5V_SW	max. 0.5 A
5	GND	-
6	V_VBUS30_H4_LVDS	-
7	GND	-
8	USB_LVDS_DN	optional
9	USB_LVDS_DP	optional
10	GND	-
11	LVDS0_RESET#	10 kΩ PD
12	LVDS0_BLT_EN	10 kΩ PD
13	LVDS0_PWR_EN	10 kΩ PD
14	LVDS_PWM	-

### 3.3.10 HDMI

The HDMI\_TX interface of the TQMa8MPxL is provided on the MBa8MP-RAS314 on an HDMI connector. Between TQMa8MPxL and HDMI socket is a "HDMI signal conditioning chip", which converts the levels and provides ESD protection. The HDMI\_ARC\_N and HDMI\_ARC\_P signals have capacitors between the module and the connector according to the EARC specification.

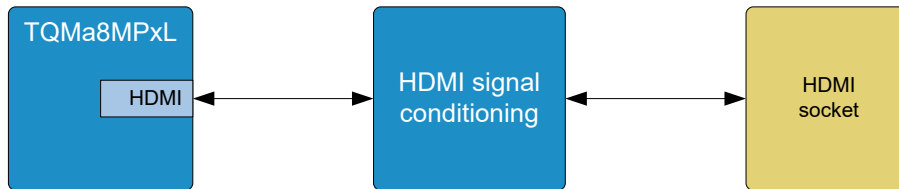

Figure 14: Block diagram HDMI

Table 13: Pinout HDMI connector, X9

Pin	Signal	Remark
1	HDMI_DATA2_P	–
2	GND	–
3	HDMI_DATA2_N	–
4	HDMI_DATA1_P	–
5	GND	–
6	HDMI_DATA1_N	–
7	HDMI_DATA0_P	–
8	GND	–
9	HDMI_DATA0_N	–
10	HDMI_CLK_P	–
11	GND	–
12	HDMI_CLK_N	–
13	HDMI_CEC	–
14	HDMI_ARC_P	–
15	HDMI_DDC_SCL	1.87 kΩ PU to HDMI_5V_OUT
16	HDMI_DDC_SDA	1.87 kΩ PU to HDMI_5V_OUT
17	GND	–
18	HDMI_5V_OUT	max. 0.5 A
19	HDMI_ARC_N	–
M1...M4	Shield/GND	–

### 3.3.11 Audio

A Texas Instruments TLV320 audio codec is assembled. It is configured via SAI5 and controlled by the I2C4 bus. The audio codec provides microphone (mono) and headphone at a 3.5 mm jack on the MBa8MP-RAS314. The supply voltage and signal level operate at 1.8 V. The jack socket is ESD protected. Headphone can become Line out by replacement of resistors R75/76 to R72/74.

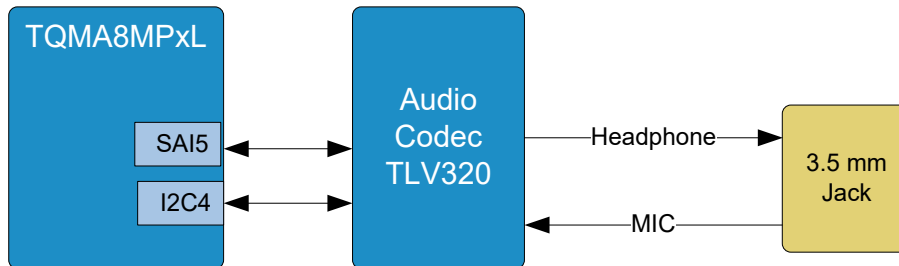

Figure 15: Block diagram audio interface

Table 14: Pinout audio connector X3

Pin	Signal	Remark
1	MIC_IN	-
4A, 4B	HEADPHONE_L	Optional connection to LOL
3	HEADPHONE_R	Optional connection to LOR
2	AGND_AUDIO	-

### 3.3.12 ECSPI

The ECSPI3 interface signals from the TQMa8MPxL are connected to the GPIO header X1. There they can be also used as GPIO control signals.

### 3.3.13 SPDIF

The SPDIF interface is not used as such on the MBa8MP-RAS314, but can be provided on the GPIO header if required. By default these module signals are configured as I2C5 and GPIO.

Table 15: SPDIF signal usage

TQMa8MPxL signal	MBa8MP-RAS314 usage	Remark
SPDIF_EXT_CLK	GPIO21	-
SPDIF_IN	GPIO2 / I2C5_SDA	2.2 kΩ PU to V_3V3_MB
SPDIF_OUT	GPIO3 / I2C5_SCL	2.2 kΩ PU to V_3V3_MB

### 3.3.14 GPT

The MBa8MP-RAS314 provides up to three general purpose timer signals. They are connected to the GPIO header.

### 3.3.15 PWM

The MBa8MP-RAS314 provides two PWM signals. They are connected to the GPIO header.

### 3.3.16 UART

The MBa8MP-RAS314 provides one UART interface connected to the GPIO header. The interface includes besides RXD and TXD also CTS and RTS signals.



### 3.3.17 USDHC

The USDHC1 interface of the TQMa8MPxL is provided at the GPIO header of the MBa8MP-RAS314. It can be used as a 4-bit wide SDIO interface.

### 3.3.18 GPIO header

Nearly all GPIOs provided by the TQMa8MPxL are used as control signals on the MBa8MP-RAS314 and are therefore not available. GPIOs can however be configured from signals available at the pin header. The GPIO signal level is 3.3 V.

A complete list of all possible GPIO pins can be found in the i.MX 8M Plus data sheet (1).

Table 16: Pinout GPIO header, X1

Alternative	Signal	Pin	Pin	Signal	Alternative
V_3V3_MB		1	2	V_5V_SW	
GPIO2 <sup>1</sup>	I2C5_SDA	3	4	GND	
GPIO3 <sup>1</sup>	I2C5_SCL	5	6	GND	
GPIO4	GPT1_CLK	7	8	UART1_TXD	GPIO14
GND		9	10	UART1_RXD	GPIO15
GPIO17	UART1_RTS	11	12	GPIO18	
GPIO27	USDHC1_DATA3	13	14	GND	
GPIO22	USDHC1_CLK	15	16	USDHC1_CMD	GPIO23
V_3V3_MB		17	18	USDHC1_DATA0	GPIO24
GPIO10	ECSPI3_MOSI	19	20	GND	
GPIO9	ECSPI3_MISO	21	22	USDHC1_DATA1	GPIO25
GPIO11	ECSPI3_SCLK	23	24	(SS1)	GPIO8
GND		25	26	ECSPI3_SS0	GPIO7
GPIO0	I2C3_SDA (ID)	27	28	I2C3_SCL (ID)	GPIO1
GPIO5	GPT2_CLK	29	30	GND	
GPIO6	GPT3_CLK	31	32	PWM3	GPIO12
GPIO13	PWM4	33	34	GND	
GPIO19		35	36	UART1_CTS	GPIO16
GPIO26	USDHC1_DATA2	37	38	GPIO20	
GND		39	40	GPIO21	

<sup>1</sup> 2.2 kΩ PU to V\_3V3\_MB

### 3.4 User interfaces and diagnostic

#### 3.4.1 Boot Mode configuration

The Boot Mode is set with the 4-fold DIP switch S4 at the four i.MX 8M Plus pins Boot\_Mode[3:0]. Information on the boot configuration of the i.MX 8M Plus can be found in the i.MX 8M Plus documentation; see Table 31.

Table 17: Boot Source options TQMa8MPxL

Boot Mode[3:0]	Boot Source
0 0 0 0	Boot from eFuses
0 0 0 1	USB Serial Downloader
0 0 1 0	Boot from eMMC (USDHC3)
0 0 1 1	Boot from SD card (USDHC2)
0 1 0 x	Boot from NAND (not supported)
0 1 1 0	Boot from QSPI (3-Byte Read)
0 1 1 1	Boot from Hyperflash 3.3 V (not supported)
1 0 0 0	Boot from eCSPI (not supported)

#### 3.4.2 Reset buttons

More information can be found in chapter 3.1.6

#### 3.4.3 Status LEDs

The MBa8MP-RAS314 offers diagnosis and status LEDs (plus the ones in the RJ45 connectors) to signal the system status.

Table 18: Status LEDs

Interface	Ref.	Colour	Indication
USB	V6	Green	Status V_VBUS30_H1 (lit when USB 3.0 port 1 is active)
	V7	Green	Status V_VBUS30_H2 (lit when USB 3.0 port 2 is active)
	V8	Green	Status V_VBUS30_H3 (lit when USB 3.0 port 3 is active)
	V9	Green	Status V_VBUS30_H4 (lit when USB 3.0 port 4 is active)
USB debug	V5	Green	Status 3.45 V Debug (lit when 3.45 V of Silicon Labs chip is active)
User LED	V2	Green	USER_LED1 (lit when ENET_RX_ER is active)
	V3	Orange	USER_LED2 (lit when ENET_TX_ER is active)
Power	V11	Green	Status V_5V_MOD (lit when active)
	V12	Green	Status V_3V3_MB (lit when active)
	V13	Green	Status 12 V MBa8MP-RAS314 (lit when 12 V for MBa8MP-RAS314 is active)
	V14	Green	Status V_5V_SW (lit when active)
	V15	Green	Status V_1V8 (lit when active)
Reset	V1	Red	Reset LED (lit when RESET_OUT# is low)
SD-Card	V4	Green	Status V_3V3_SD (lit when active)
Ethernet	X15	Green/Green	ETH0 - Link/Activity
	X16	Green/Green	ETH1 - Link/Activity

### 3.4.4 JTAG®

The JTAG® port of the i.MX 8M Plus is routed to a standard ARM® 10-pin JTAG® connector (X17) on the MBa8MP-RAS314. JTAG\_SRST# is connected to RESET\_IN# via a buffer. The same reset can be executed as with reset button S1. The JTAG® interface is not ESD protected.

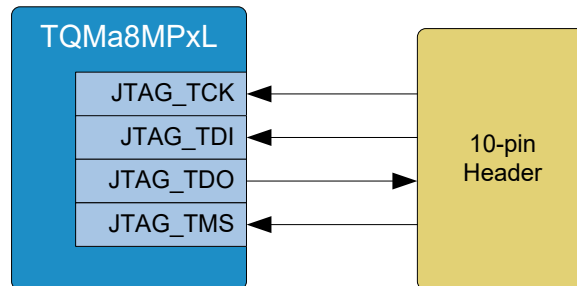

Figure 16: Block diagram JTAG

The following table shows the JTAG® connector pinout.

Table 19: Pinout JTAG® pin header, X17

Pin	Signal	Remark
1	V <sub>ref</sub> / VCC	3.3 V
2	JTAG_TMS	–
3	GND	–
4	JTAG_TCK	–
5	GND	–
6	JTAG_TDO	–
7	Key	(NC)
8	JTAG_TDI	–
9	GND_DETECT	10 kΩ PD
10	JTAG_SRST#	RESET_IN#, 10 kΩ PU

## 4. SOFTWARE

No software is required for the MBa8MP-RAS314. Suitable software is only required on the TQMa8MPxL and is not a part of this Preliminary User's Manual. More information can be found in the [TQ-Support Wiki for the TQMa8MPxL](#).

## 5. MECHANICS

### 5.1 MBa8MP-RAS314 dimensions

The MBa8MP-RAS314 has overall dimensions (length × width) of 100 mm × 100 mm. The height without heatspreader and heatsink is approximately 20.5 mm. The MBa8MP-RAS314 including TQMa8MPxL weighs approximately 95 grams.

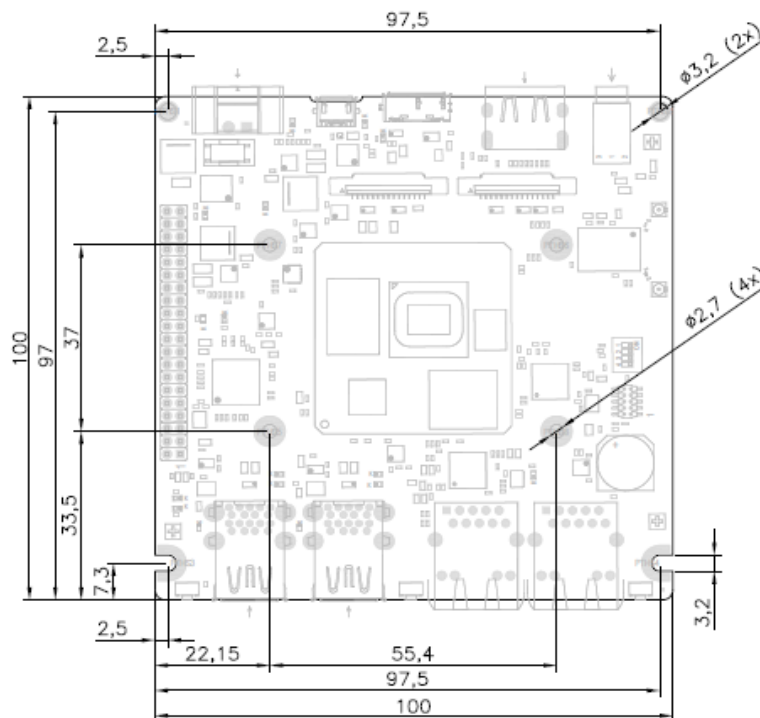

Figure 17: Dimensions MBa8MP-RAS314

### 5.2 Embedding in the overall system

The MBa8MP-RAS314 serves as a design base for customer products, as well as a platform to support during development.

### 5.3 Thermal management

The combination of MBa8MP-RAS314 and TQMa8MPxL has a power consumption of approximately TBD watts. Further power consumption occurs mainly at externally connected devices.

#### Attention: TQMa8MPxL heat dissipation



The i.MX 8M Plus belongs to a performance category in which a cooling system is essential. It is the user's sole responsibility to define a suitable heat sink (weight and mounting position) depending on the specific mode of operation (e.g., dependence on clock frequency, stack height, airflow, and software). Particularly the tolerance chain (PCB thickness, board warpage, BGA balls, BGA package, thermal pad, heatsink) as well as the maximum pressure on the TQMa8MPxL must be taken into consideration when connecting the heat sink. The TQMa8MPxL is not the highest component. Inadequate cooling connections can lead to overheating of the TQMa8MPxL or the MBa8MP-RAS314 and thus malfunction, deterioration or destruction.

## 5.4 Component placement & labeling

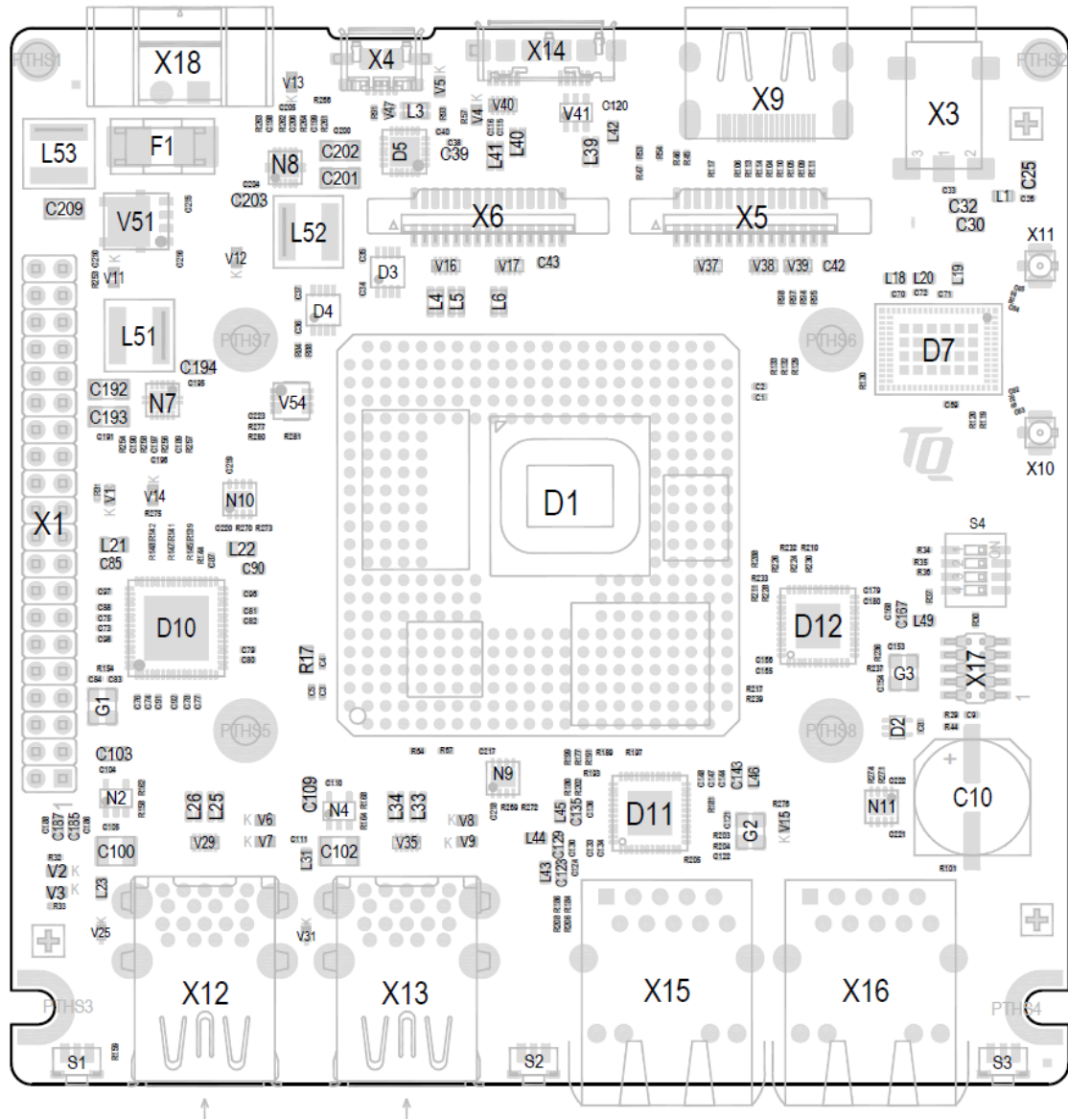

Figure 18: MBa8MP-RAS314 component placement top

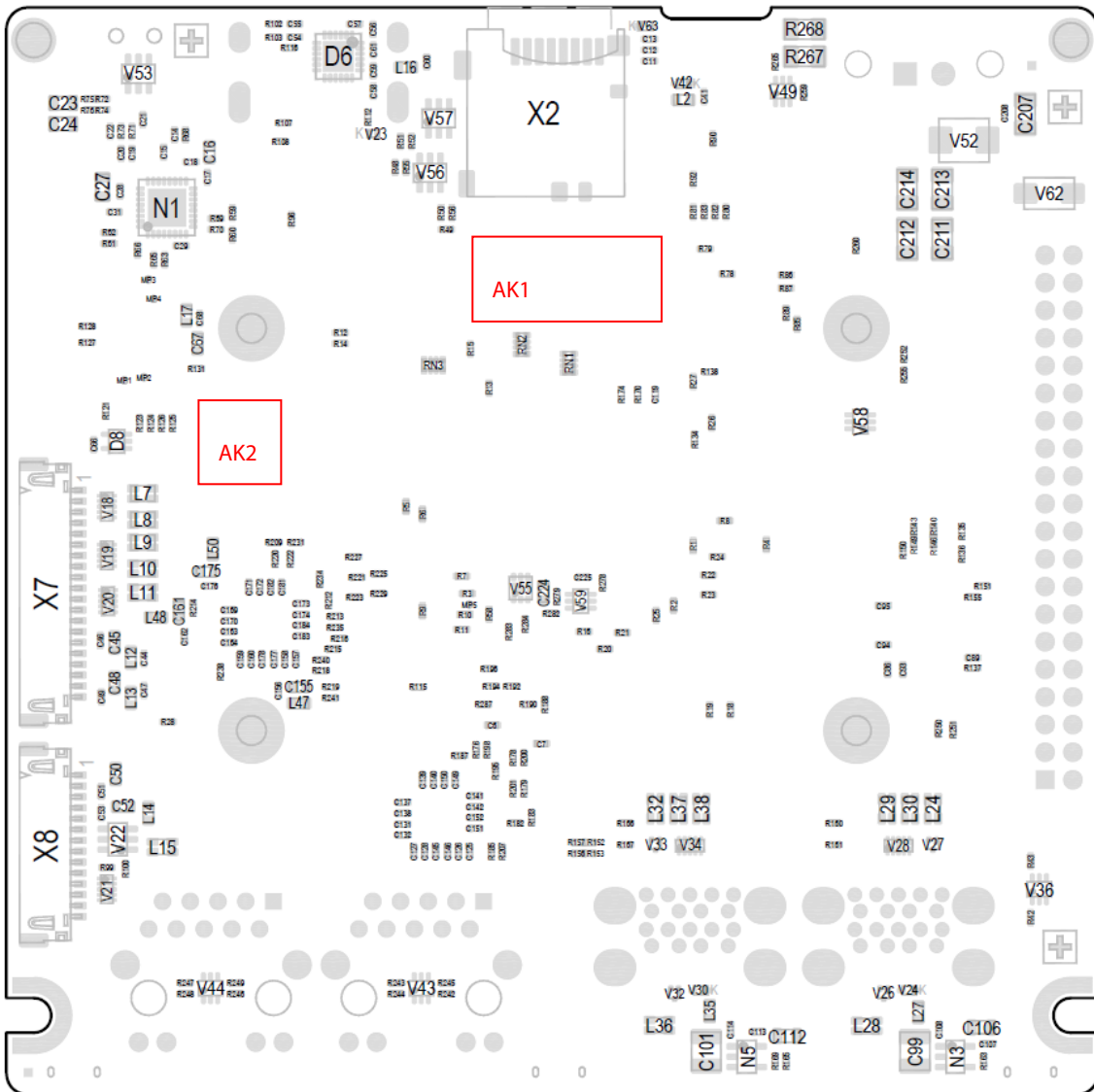

Figure 19: MBa8MP-RAS314 component placement bottom

The labels on the MBa8MP-RAS314 show the following information:

Table 20: Labels on MBa8MP-RAS314

Label	Content
AK1	MBa8MP-RAS314 version and revision, tests performed
AK2	Serial number



## 6. SAFETY REQUIREMENTS AND PROTECTIVE REGULATIONS

### 6.1 EMC

Since the MBa8MP-RAS314 is a development platform, no EMC tests have been performed.

### 6.2 ESD

Most interfaces provide ESD protection. Details are to be taken from the MBa8MP-RAS314 schematics.

### 6.3 Operational safety and personal security

Tests for operational safety and personal protection were not carried out due to the voltages  $\leq 30$  V DC.

### 6.4 Cyber Security

A Threat Analysis and Risk Assessment (TARA) must always be performed by the customer for their individual end application, as the MBa8MP-RAS314 is only a sub-component of an overall system.

### 6.5 Intended Use

TQ DEVICES, PRODUCTS AND ASSOCIATED SOFTWARE ARE NOT DESIGNED, MANUFACTURED OR INTENDED FOR USE OR RESALE FOR THE OPERATION IN NUCLEAR FACILITIES, AIRCRAFT OR OTHER TRANSPORTATION NAVIGATION OR COMMUNICATION SYSTEMS, AIR TRAFFIC CONTROL SYSTEMS, LIFE SUPPORT MACHINES, WEAPONS SYSTEMS, OR ANY OTHER EQUIPMENT OR APPLICATION REQUIRING FAIL-SAFE PERFORMANCE OR IN WHICH THE FAILURE OF TQ PRODUCTS COULD LEAD TO DEATH, PERSONAL INJURY, OR SEVERE PHYSICAL OR ENVIRONMENTAL DAMAGE. (COLLECTIVELY, "HIGH RISK APPLICATIONS")

You understand and agree that your use of TQ products or devices as a component in your applications are solely at your own risk. To minimize the risks associated with your products, devices and applications, you should take appropriate operational and design related protective measures.

You are solely responsible for complying with all legal, regulatory, safety and security requirements relating to your products. You are responsible for ensuring that your systems (and any TQ hardware or software components incorporated into your systems or products) comply with all applicable requirements. Unless otherwise explicitly stated in our product related documentation, TQ devices are not designed with fault tolerance capabilities or features and therefore cannot be considered as being designed, manufactured or otherwise set up to be compliant for any implementation or resale as a device in high risk applications. All application and safety information in this document (including application descriptions, suggested safety precautions, recommended TQ products or any other materials) is for reference only. Only trained personnel in a suitable work area are permitted to handle and operate TQ products and devices. Please follow the general IT security guidelines applicable to the country or location in which you intend to use the equipment.

### 6.6 Export Control and Sanctions Compliance

The customer is responsible for ensuring that the product purchased from TQ is not subject to any national or international export/import restrictions. If any part of the purchased product or the product itself is subject to said restrictions, the customer must procure the required export/import licenses at its own expense. In the case of breaches of export or import limitations, the customer indemnifies TQ against all liability and accountability in the external relationship, irrespective of the legal grounds. If there is a transgression or violation, the customer will also be held accountable for any losses, damages or fines sustained by TQ. TQ is not liable for any delivery delays due to national or international export restrictions or for the inability to make a delivery as a result of those restrictions. Any compensation or damages will not be provided by TQ in such instances.

The classification according to the European Foreign Trade Regulations (export list number of Reg. No. 2021/821 for dual-use-goods) as well as the classification according to the U.S. Export Administration Regulations in case of US products (ECCN according to the U.S. Commerce Control List) are stated on TQ's invoices or can be requested at any time. Also listed is the Commodity code (HS) in accordance with the current commodity classification for foreign trade statistics as well as the country of origin of the goods requested/ordered.



## 6.7 Warranty

TQ-Systems GmbH warrants that the product, when used in accordance with the contract, fulfills the respective contractually agreed specifications and functionalities and corresponds to the recognized state of the art.

The warranty is limited to material, manufacturing and processing defects. The manufacturer's liability is void in the following cases:

- Original parts have been replaced by non-original parts.
- Improper installation, commissioning or repairs.
- Improper installation, commissioning or repair due to lack of special equipment.
- Incorrect operation
- Improper handling
- Use of force
- Normal wear and tear

## 7. CLIMATIC AND OPERATIONAL CONDITIONS

In general reliable operation is given when the following conditions are met:

Table 21: Climatic and operational conditions MBa8MP-RAS314

Parameter	Range	Remark
Ambient temperature	TBD	
Storage temperature	TBD	
Relative humidity (operation / storing)	TBD	Not condensing

Attention: TQMa8MPxL heat dissipation	
	<p>The i.MX 8M Plus belongs to a performance category in which a cooling system is essential. It is the user's sole responsibility to define a suitable heat sink (weight and mounting position) depending on the specific mode of operation (e.g., dependence on clock frequency, stack height, airflow, and software).</p> <p>Particularly the tolerance chain (PCB thickness, board warpage, BGA balls, BGA package, thermal pad, heatsink) as well as the maximum pressure on the TQMa8MPxL must be taken into consideration when connecting the heat sink.</p> <p>The TQMa8MPxL is not the highest component. Inadequate cooling connections can lead to overheating of the TQMa8MPxL or the MBa8MP-RAS314 and thus malfunction, deterioration or destruction.</p>

### 7.1 Protection against external effects

Protection class IP00 was defined for the MBa8MP-RAS314. There is no protection against foreign objects, touch or humidity.

### 7.2 Reliability and service life

No detailed MTBF calculation has been done for the MBa8MP-RAS314.

The MBa8MP-RAS314 is designed to be insensitive to vibration and impact.





## 8. ENVIRONMENT PROTECTION

### 8.1 RoHS

The MBa8MP-RAS314 is manufactured RoHS compliant. All components, assemblies and soldering processes are RoHS compliant.

### 8.2 WEEE®

The final distributor is responsible for compliance with the WEEE® regulation. Within the scope of the technical possibilities, the MBa8MP-RAS314 was designed to be recyclable and easy to repair.

### 8.3 REACH®

The EU-chemical regulation 1907/2006 (REACH® regulation) stands for registration, evaluation, certification and restriction of substances SVHC (Substances of very high concern, e.g., carcinogen, mutagen and/or persistent, bio accumulative and toxic). Within the scope of this juridical liability, TQ-Systems GmbH meets the information duty within the supply chain with regard to the SVHC substances, insofar as suppliers inform TQ-Systems GmbH accordingly.

### 8.4 EuP

The Ecodesign Directive, also Energy using Products (EuP), is applicable to products for the end user with an annual quantity >200,000. The MBa8MP-RAS314 must therefore always be seen in conjunction with the complete device. The available standby and sleep modes of the components on the MBa8MP-RAS314 enable compliance with EuP requirements for the MBa8MP-RAS314.

### 8.5 Statement on California Proposition 65

California Proposition 65, formerly known as the Safe Drinking Water and Toxic Enforcement Act of 1986, was enacted as a ballot initiative in November 1986. The proposition helps protect the state's drinking water sources from contamination by approximately 1,000 chemicals known to cause cancer, birth defects, or other reproductive harm ("Proposition 65 Substances") and requires businesses to inform Californians about exposure to Proposition 65 Substances.

The TQ device or product is not designed or manufactured or distributed as consumer product or for any contact with end-consumers. Consumer products are defined as products intended for a consumer's personal use, consumption, or enjoyment. Therefore, our products or devices are not subject to this regulation and no warning label is required on the assembly. Individual components of the assembly may contain substances that may require a warning under California Proposition 65. However, it should be noted that the Intended Use of our products will not result in the release of these substances or direct human contact with these substances. Therefore you must take care through your product design that consumers cannot touch the product at all and specify that issue in your own product related documentation. TQ reserves the right to update and modify this notice as it deems necessary or appropriate.

### 8.6 Packaging

The MBa8MP-RAS314 is delivered in reusable packaging.

### 8.7 Batteries

The MBa8MP-RAS314 does not require a battery and therefore does not use batteries containing mercury (Hg), cadmium (Cd) or lead (Pb).

### 8.8 Other entries

By environmentally friendly processes, production equipment and products, we contribute to the protection of our environment. To be able to reuse the MBa8MP-RAS314, it is produced in such a way (a modular construction) that it can be easily repaired and disassembled. The energy consumption of the MBa8MP-RAS314 is minimised by suitable measures.

Because currently there is still no technical equivalent alternative for printed circuit boards with bromine-containing flame protection (FR-4 material), such printed circuit boards are still used. No use of PCB containing capacitors and transformers (polychlorinated biphenyls).

These points are an essential part of the following laws:

- The law to encourage the circular flow economy and assurance of the environmentally acceptable removal of waste as at 27.9.94 (Source of information: BGBl I 1994, 2705)
- Regulation with respect to the utilization and proof removal as at 1.9.96 (Source of information: BGBl I 1996, 1382, (1997, 2860))
- Regulation with respect to the avoidance and utilization of packaging waste as at 21.8.98 (Source of information: BGBl I 1998, 2379)
- Regulation with respect to the European Waste Directory as at 1.12.01 (Source of information: BGBl I 2001, 3379)

This information is to be seen as notes. Tests or certifications were not carried out in this respect.

## 9. APPENDIX

### 9.1 Acronyms and definitions

The following acronyms and abbreviations are used in this document:

Table 22: Acronyms

Acronym	Meaning
ADC	Analog/Digital Converter
AI	Artificial Intelligence
ARM®	Advanced RISC Machine
BGA	Ball Grid Array
BIOS	Basic Input/Output System
CAN	Controller Area Network
CAN FD	Controller Area Network Flexible Data-Rate
CCM	Clock Control Module
CPU	Central Processing Unit
CSI	Camera Serial Interface
DIP	Dual In-line Package
DNC	Do Not Connect
DP	DisplayPort
DSI	Display Serial Interface
eCSPI	enhanced Capability Serial Peripheral Interface
eDP	embedded DisplayPort
EEPROM	Electrically Erasable Programmable Read-Only Memory
EMC	Electromagnetic Compatibility
eMMC	embedded Multimedia Card (Flash)
ESD	Electrostatic Discharge
EU	European Union
EuP	Energy using Products
FPS	Frames Per Second
FR-4	Flame Retardant 4
GP	General Purpose
GPIO	General Purpose Input/Output
GPT	General Purpose Timer
HD	High Density (graphics)
HDMI	High-Definition Multimedia Interface
HSS	High-Side Switch
I	Input
I/O	Input/Output
I <sup>2</sup> C	Inter-Integrated Circuit
IEEE®	Institute of Electrical and Electronics Engineers
IP00	Ingress Protection 00
JTAG®	Joint Test Action Group
LCD	Liquid Crystal Display
LED	Light Emitting Diode
LGA	Land Grid Array
LPDDR4	Low-Power DDR4
LVDS	Low Voltage Differential Signal

## 9.1 Acronyms and definitions (continued)

Table 23: Acronyms (continued)

Acronym	Meaning
MAC	Media Access Controller
MIC	Microphone
MIPI	Mobile Industry Processor Interface
ML	Machine Learning
MTBF	Mean operating Time Between Failures
NAND	Not-And (flash memory)
NC	Not Connected
NMI	Non-Maskable Interrupt
NOR	Not-Or
NP	Not Placed
O	Output
OTG	On-The-Go
P	Power
PCB	Printed Circuit Board
PCIe	Peripheral Component Interconnect express
PCMCIA	People Can't Memorize Computer Industry Acronyms
PD	Pull-Down
PHY	Physical (layer of the OSI model)
PMIC	Power Management Integrated Circuit
PU	Pull-Up
PWM	Pulse-Width Modulation
QSPI	Quad Serial Peripheral Interface
REACH®	Registration, Evaluation, Authorisation (and restriction of) Chemicals
RGMII	Reduced Gigabit Media-Independent Interface
RJ45	Registered Jack 45
RoHS	Restriction of (the use of certain) Hazardous Substances
RPM	Revolutions Per Minute
RTC	Real-Time Clock
SAI	Serial Audio Interface
SD	Secure Digital
SDHC	Secure Digital High Capacity
SDRAM	Synchronous Dynamic Random Access Memory
SIM	Subscriber Identification Module
SPDIF	Sony-Philips Digital Interface Format
SVHC	Substances of Very High Concern
TSE	Trust Secure Element
UART	Universal Asynchronous Receiver/Transmitter
UHS	Ultra-High Speed
UM	User's Manual
UN	United Nations
USB	Universal Serial Bus
uSDHC	Ultra-Secured Digital Host Controller
WEEE®	Waste Electrical and Electronic Equipment
ZIF	Zero Insertion Force



## 9.2 References

Table 23: Further applicable documents

No.	Name	Rev. / Date	Company
(1)	i.MX 8M Plus Applications Processor Data Sheet	Rev. 1 / 08/2021	<a href="#">NXP</a>
(2)	i.MX 8M Plus Applications Processor Reference Manual	Rev. 1/ 03/2021	<a href="#">NXP</a>
(3)	Mask Set Errata i.MX 8M Plus	– current –	<a href="#">NXP</a>
(4)	TQMa8MPxL User's Manual	– current –	<a href="#">TQ-Systems</a>
(5)	TQMa8MPxL Support Wiki	– current –	<a href="#">TQ-Systems</a>

