



ABox-93xxLA Preliminary User's Guide

ABox-93xxLA UG 0004
25.06.2026





TABLE OF CONTENTS

| | | |
|-------|---|----|
| 1. | IMPORTANT INFORMATION | 1 |
| 1.1 | General | 1 |
| 1.2 | Symbols and Typographic Conventions..... | 1 |
| 1.3 | Before You Start..... | 1 |
| 1.4 | Intended Use | 1 |
| 1.5 | Duty Of Care..... | 2 |
| 1.6 | Limited Warranty..... | 2 |
| 1.7 | Liability and Warranty Obligation | 2 |
| 1.8 | Safety Guidelines..... | 2 |
| 1.9 | Grounding Considerations..... | 2 |
| 1.10 | ESD Considerations | 3 |
| 1.11 | Handling the ABox-93xxLA | 3 |
| 1.12 | Coin Cell Battery | 3 |
| 2. | ABOUT THIS MANUAL..... | 4 |
| 2.1 | Copyright and Licence Expenses..... | 4 |
| 2.2 | Registered Trademarks..... | 4 |
| 2.3 | Disclaimer | 4 |
| 2.4 | Imprint..... | 4 |
| 2.5 | Service, Support, and RMA..... | 4 |
| 3. | INTRODUCTION..... | 5 |
| 3.1 | Functional Overview | 5 |
| 3.2 | ABox-93xxLA Versions | 5 |
| 4. | FUNCTIONAL SPECIFICATION..... | 7 |
| 4.1 | Supply Voltage Characteristics | 7 |
| 4.2 | Power Consumption Specification | 7 |
| 4.3 | Environmental Specification..... | 7 |
| 4.4 | Connectors and Interfaces | 8 |
| 4.4.1 | POWER SUPPLY CONNECTOR..... | 8 |
| 4.4.2 | USB Host Interfaces..... | 8 |
| 4.4.3 | Gigabit Ethernet | 8 |
| 4.4.4 | Power and Reset Button..... | 8 |
| 4.4.5 | SMA Antenna Connectors | 8 |
| 4.4.6 | M.2 Extension Sockets | 8 |
| 4.4.7 | MicroSD Card Socket..... | 9 |
| 4.4.8 | Reliability and service life..... | 9 |
| 5. | MECHANICS..... | 10 |
| 5.1 | Dimensions | 10 |
| 5.2 | Mounting | 10 |
| 6. | REGULATORY INFORMATION | 11 |
| 6.1 | EU Compliance with Electromagnetic Compatibility Directive EC-Declaration of Conformity | 11 |
| 6.2 | Cyber Security | 11 |
| 6.3 | Export Control and Sanctions Compliance | 11 |
| 6.4 | Warranty..... | 11 |
| 6.5 | Statement on California Proposition 65..... | 11 |
| 7. | WEEE AND RECYCLING | 12 |
| 7.1 | WEEE..... | 12 |
| 7.2 | Recycling..... | 12 |



TABLE DIRECTORY

| | | |
|----------|-------------------------------------|---|
| Table 1: | Terms and Conventions | 1 |
| Table 2: | ABox-93xxLA Chassis Option | 5 |
| Table 3: | ABox-93xxLA Standard Versions | 6 |
| Table 4: | TQMa93xxLA Module Versions | 6 |
| Table 5: | Pinout Power-In Connector | 8 |
| Table 6: | Ethernet LEDs | 8 |

FIGURE DIRECTORY

| | | |
|-----------|--|----|
| Figure 1: | DC Power Supply Connector | 8 |
| Figure 2: | RJ45 Connectors | 8 |
| Figure 3: | ABox-93xxLA (without connectors), Dimensions (mm), Bottom View | 10 |
| Figure 4: | ABox-93xxLA, Dimensions of Mounting Holes (mm), Bottom View | 10 |

REVISION HISTORY

| Rev. | Date | Name | Pos. | Modification |
|------|------------|---------|--------------------------------------|--|
| 0001 | 10.12.2025 | Kreuzer | | First edition |
| 0002 | 20.01.2026 | Kreuzer | All | Typo |
| 0003 | 18.03.2026 | Kreuzer | 1.4 4.1 (old) 4.1 (new) 4.3 | Additional notes Chapter numbering corrected Update to standards and power supply recommendations Additional specifications |
| 0004 | 25.06.2026 | Kreuzer | Table 3 7.2 | Clarification regarding power consumption Chapter enhanced |







1. IMPORTANT INFORMATION

1.1 General

Be sure to follow the tips given in this Preliminary User's Guide to make best use of the ABox-93xxLA. Failure to do so might lead to discomfort or injury, or cause the ABox-93xxLA to fail.

1.2 Symbols and Typographic Conventions

Table 1: Terms and Conventions

| Symbol | Meaning |
|---|---|
|  | This symbol represents the handling of electrostatic-sensitive modules and / or components. These components are often damaged / destroyed by the transmission of a voltage higher than about 50 V. A human body usually only experiences electrostatic discharges above approximately 3,000 V. |
|  | This symbol indicates the possible use of voltages higher than 24 V. Please note the relevant statutory regulations in this regard. Non-compliance with these regulations can lead to serious damage to your health and also cause damage / destruction of the component. |
|  | This symbol indicates a possible source of danger. Acting against the procedure described can lead to possible damage to your health and / or cause damage / destruction of the material used. |
|  | This symbol represents important details or aspects for working with TQ-products. |

1.3 Before You Start

This Preliminary User's Guide must be carefully read and completely understood before you start working with the ABox-93xxLA. This Preliminary User's Guide provides information, which is essential for proper operation of the ABox-93xxLA. General safety instructions must be adhered to and only trained and authorized personnel is permitted to work with the ABox-93xxLA.

1.4 Intended Use

TQ DEVICES, PRODUCTS AND ASSOCIATED SOFTWARE ARE NOT DESIGNED, MANUFACTURED OR INTENDED FOR USE OR RESALE FOR THE OPERATION IN NUCLEAR FACILITIES, AIRCRAFT OR OTHER TRANSPORTATION NAVIGATION OR COMMUNICATION SYSTEMS, AIR TRAFFIC CONTROL SYSTEMS, LIFE SUPPORT MACHINES, WEAPONS SYSTEMS, OR ANY OTHER EQUIPMENT OR APPLICATION REQUIRING FAIL-SAFE PERFORMANCE OR IN WHICH THE FAILURE OF TQ PRODUCTS COULD LEAD TO DEATH, PERSONAL INJURY, OR SEVERE PHYSICAL OR ENVIRONMENTAL DAMAGE. (COLLECTIVELY, "HIGH RISK APPLICATIONS")

You understand and agree that your use of TQ products or devices as a component in your applications are solely at your own risk. To minimize the risks associated with your products, devices and applications, you should take appropriate operational and design related protective measures.

You are solely responsible for complying with all legal, regulatory, safety and security requirements relating to your products. You are responsible for ensuring that your systems (and any TQ hardware or software components incorporated into your systems or products) comply with all applicable requirements. Unless otherwise explicitly stated in our product related documentation, TQ devices are not designed with fault tolerance capabilities or features and therefore cannot be considered as being designed, manufactured or otherwise set up to be compliant for any implementation or resale as a device in high risk applications. All application and safety information in this document (including application descriptions, suggested safety precautions, recommended TQ products or any other materials) is for reference only. Only trained personnel in a suitable work area are permitted to handle and operate TQ products and devices. Please follow the general IT security guidelines applicable to the country or location in which you intend to use the equipment.

This device is not suitable for use in areas where children may be present.



1.5 Duty Of Care

It must be ensured that the ABox-93xxLA is only used in environments, which meet the specification of the ABox-93xxLA. The Preliminary User's Guide has to be completely read and understood and the personnel is authorized and trained regarding standards, regulations and instructions. It also has to be ensured, that the ABox-93xxLA is mounted, operated and maintained according to the instruction of this Preliminary User's Guide. All applicable national and international regulations and standards have to be obeyed.

1.6 Limited Warranty

Parts which wear out naturally are excluded from the warranty beyond that provided by law. This applies to e.g., coin cell batteries.

1.7 Liability and Warranty Obligation

TQ-Systems GmbH shall be exempted from the statutory accident liability obligation in case the user does not observe the information provided in this Preliminary User's Guide or the warnings on the device. In the event of damage caused by failure to observe the information provided in this Preliminary User's Guide or the warnings on the device, TQ-Systems GmbH shall not be required to honour the warranty even during the warranty period and shall be exempted from the statutory accident liability obligation.

1.8 Safety Guidelines

Use the following safety guidelines to protect your ABox-93xxLA from potential damage and ensure your personal safety. If the following safety guidelines are not observed, it could lead to injuries to the operator and/or damage of the ABox-93xxLA. In cases of non-observance of the safety guidelines TQ-Systems GmbH is exempt from accident liability, even if the ABox-93xxLA is still under warranty. The ABox-93xxLA must be used as specified in this Preliminary User's Guide, which describes the safety guidelines for the ABox-93xxLA as well as for the operator. The place where the ABox-93xxLA is installed has to meet the requirements of the country's standards and regulations. If power cables are delivered with the ABox-93xxLA only these may be used. Ensure that there is sufficient air circulation to cool the ABox-93xxLA. Do not cover the ABox-93xxLA or mount it close to heat sources or damp places.

To completely disconnect the ABox-93xxLA from mains, the power cord has to be disconnected. Make sure the power cord is always easy accessible. Only open the ABox-93xxLA after all cables are disconnected from the ABox-93xxLA to insert or remove add-on cards.

This may only be done by qualified personnel. If add-on cards are installed in the ABox-93xxLA, all effective legal regulations and all technical data has to be adhered to. It has to be ensured, that the power consumption of add-on cards does not exceed the limitations and the current consumption specified on the label of the ABox-93xxLA. Very important! A safe operation is not possible when the ABox-93xxLA is visibly damaged or is not functioning at all. In this case the ABox-93xxLA must be switched off and it must be ensured that the ABox-93xxLA cannot be put back into operation. It is very important to ensure that the wires of power cords are sufficiently dimensioned, according to the maximum electrical specifications of the ABox-93xxLA. Standards and regulations like EN62368-1, VDE0100, EN60204, or UL508 have to be adhered to. This information helps you to safely use the ABox-93xxLA.

Follow and keep all information included with the ABox-93xxLA. The information in this Preliminary User's Guide does not alter the terms of your purchase agreement or the TQ-Systems GmbH Limited Warranty. Your safety is important to us. The ABox-93xxLA is developed to be safe and effective. Power cords, power adapters, and other features can create potential safety risks that may result in physical injury or property damage, especially if misused. To reduce these risks, follow the instructions in this Preliminary User's Guide, and observe all warnings on the ABox-93xxLA and in this Preliminary User's Guide. By carefully following the information contained in this Preliminary User's Guide and provided with the ABox-93xxLA, you can help protect yourself from hazards and create a safer environment.

Do not attempt to service the ABox-93xxLA yourself unless instructed to do so by TQ-Systems GmbH or this Preliminary User's Guide.

1.9 Grounding Considerations

Be aware, that the chassis of the ABox-93xxLA is internally connected to Digital Ground (Power Supply Connector GND). Depending on the Power Supply Unit used, it also might be connected or not to protective earth (PE).

This has to be considered, when connecting other components to the ABox-93xxLA.

The grounding of the ABox-93xxLA might also influence the electromagnetic emission of the ABox-93xxLA.

TQ-Systems GmbH recommends using the CINCON TRG30 power supply unit or equivalent, where PE is connected to GND.



1.10 ESD Considerations

To avoid damaging the ABox-93xxLA caused by ESD make sure the following measures are adhered to: Ground your workplace with e.g. anti-static mats and ground yourself with a wrist strap. Only use conductive tools when working on the ABox-93xxLA. Always handle electrostatic sensitive components at their edges, preferably wear conductive gloves. Remove the power cord from the ABox-93xxLA before inserting or removing connectors or before inserting or removing add-on cards. Don't touch the contacts of connectors. Keep your work environment tidy and free of non-conductive materials.

1.11 Handling the ABox-93xxLA

Attention: Handling the ABox-93xxLA



Improper or incorrect handling of the ABox-93xxLA can substantially reduce its life span. TQ-Systems GmbH cannot be held responsible for unauthorized modifications made by the user and the consequences thereof, which may alter the conformity of the ABox-93xxLA.

1.12 Coin Cell Battery

Attention: Coin cell battery



Danger of explosion if the coin cell battery is incorrectly replaced. Replace the coin cell battery only with a coin cell battery of the same type and size. Check for correct polarity before inserting the coin cell battery in its socket. Do not immerse into water, heat to more than +100 °C, repair or disassemble the coin cell battery. Dispose the coin cell battery as required by local ordinances or regulations.



2. ABOUT THIS MANUAL

2.1 Copyright and Licence Expenses

Copyright protected © 2026 by TQ-Systems GmbH.

This Preliminary User's Guide may not be copied, reproduced, translated, changed or distributed, completely or partially in electronic,

machine readable, or in any other form without the written consent of TQ-Systems GmbH.

The drivers and utilities for the components used as well as the BIOS are subject to the copyrights of the respective manufacturers. The licence conditions of the respective manufacturer are to be adhered to.

BIOS-licence expenses are paid by TQ-Systems GmbH and are included in the price.

Licence expenses for the operating system and applications are not taken into consideration and must be calculated / declared separately.

2.2 Registered Trademarks

TQ-Systems GmbH aims to adhere to copyrights of all graphics and texts used in all publications, and strives to use original or license-free graphics and texts.

All brand names and trademarks mentioned in the publication, including those protected by a third party, unless specified otherwise in writing, are subjected to the specifications of the current copyright laws and the proprietary laws of the present registered proprietor without any limitation. One should conclude that brand and trademarks are rightly protected by a third party.

2.3 Disclaimer

TQ-Systems GmbH does not guarantee that the information in this Preliminary User's Guide is up-to-date, correct, complete or of good quality. Nor does TQ-Systems GmbH assume guarantee for further usage of the information.

Liability claims against TQ-Systems GmbH, referring to material or non-material related damages caused, due to usage or non-usage of the information given in the Preliminary User's Guide, or due to usage of erroneous or incomplete information, are exempted,

as long as there is no proven intentional or negligent fault of TQ-Systems GmbH. TQ-Systems GmbH explicitly reserves the rights to change or add to the contents of this Preliminary User's Guide or parts of it without special notification.

2.4 Imprint

TQ-Systems GmbH

Gut Delling, Mühlstraße 2

D-82229 Seefeld

Tel: +49 8153 9308-0

Fax: +49 8153 9308-4223

Email: info@tq-group.com

Web: www.tq-group.com

2.5 Service, Support, and RMA

Please visit our website www.tq-group.com for latest product documentation, drivers, utilities and technical support.

You can register on our website www.tq-group.com to have access to restricted information and automatic update services.

For direct technical support you can contact our FAE team support@tq-group.com.

Our FAE team can also support you with additional information, which is not provided on our website.

For service/RMA, please contact our service team service@tq-group.com or your TQ sales representative.

3. INTRODUCTION

The ABox-93xxLA is a very compact Embedded Computer based on NXP i.MX93 processor series for embedded applications. The highly reliable hardware in combination with the rugged housing design enables the usage in industrial and harsh environmental conditions.

The ABox-93xxLA can be configured to meet individual customer requirements. Functionality and interfaces can be easily added using internal Mini PCIe cards. Typical applications include embedded servers and gateways, entry-level PC systems for automation, visualisation and monitoring, and all applications that demand high quality, durability and long-term availability.

3.1 Functional Overview

The following key functions are implemented in the ABox-93xxLA:

External interfaces (standard)

- 2 × Gigabit Ethernet
- 2 × USB 2.0 Host
- 1 × USB 2.0 Device
- 1 × USB Debug
- 2 × CAN
- MicroSD card socket
- Power Button & Reset Button

Internal interfaces and connection possibilities

- M.2 Key B
- M.2 Key E
- MIPI-CSI/DSI
- Micro SIM socket
- 1 × LVDS Data
- 1 × LVDS CMD
- 2 × Extension

Power Supply

- Input voltage range: 16 V DC to 32 V DC

3.2 ABox-93xxLA Versions

Currently the ABox-93xxLA is available in single configuration. The following table shows the details:

Table 2: ABox-93xxLA Chassis Option





Table 3: ABox-93xxLA Standard Versions

| ABox | TQMa93xxLA | LPDDR4 SDRAM | Mass Storage | Power Consumption | Temp. Range |
|-------------|---------------|--------------|--------------|--------------------------|------------------|
| ABox-93xxLA | TQMa9352LA-AA | 1 GByte | 8 GByte eMMC | typ. 4 W (max. 8.4 W) | -25 °C to +70 °C |

The ABox-93xxLA focuses on individual / customer specific configurations and individual branding. For this reason several other TQMa93xxLA modules are available on request:

Table 4: TQMa93xxLA Module Versions

| Module | CPU | LPDDR4 SDRAM | eMMC | Temperature Module |
|---------------|---|--------------|---------|--|
| TQMa9352LA-AA | NXP i.MX 9352 (2 x 1.7 GHz Cortex-A55, 1 x 250 MHz Cortex-M33) | 1 GByte | 8 GByte | -25 °C to +85 °C / -40 °C to +85 °C |

More configurations are possible:

Memory:

- LPDDR4: Up to 2 GByte
- NOR: Up to 256 MByte
- eMMC Flash: Up to 256 GByte
- EEPROM: 0/64-Kbit

Add-ons:

- On request, e.g.:
 - Secure Element SE050
 - Gyroscope sensor
 - WiFi (M.2 Key E)
 - Cellular modem (M.2 Key B)

Note: Add-on cards

| | |
|---|--|
|  | The device must be re-certified if add-on cards are installed. |
|---|--|

4. FUNCTIONAL SPECIFICATION

4.1 Supply Voltage Characteristics

The ABox-93xxLA supports a wide-range voltage input of 16 V DC to 32 V DC.

| Attention: Power requirement | |
|---|--|
|  | Using a power adapter with IEC/EN62368-1 PS2 (<100 W) certification is compulsory. |

TQ-Systems GmbH recommends the AC Adapter TRG30R180V from CINCON (Input 90 to 264 V AC) for applications **up to +45 °C**. A Power kit is available on request.

At higher ambient temperatures or other environmental conditions, a suitable power supply has to be chosen.

4.2 Power Consumption Specification

The power consumption of the system significantly depends on the configuration and the connected devices (module, mass storage devices, USB devices etc.). The maximum input current of the ABox-93xxLA is limited to 5 A by a fuse. All USB devices connected to the ABox-93xxLA should not exceed 5 W in total.

| Note: Power requirement | |
|---|---|
|  | The power supply for the ABox-93xxLA must be configured with enough reserve. When selecting the power supply, the maximum power consumption of all components must be taken into account. |

4.3 Environmental Specification

The following temperature parameters were determined by qualification tests (standard configurations without add-on cards, but with I-Temp mass storage):

- Operating temperature: -25 °C to +70 °C (standard range)
 -40 °C to +70 °C (extended range)
- Relative humidity (operating / storage): 10 % to 90 % (not condensing)
- Operating altitude: Less than 5000 m
- Installation height above floor: Less than 2 m

When I/O extension modules or SSDs are selected, attention has to be paid to their storage and operating temperature limits. The temperature inside the ABox-93xxLA differs from the ambient temperature. The modules should be specified for up to +85 °C. If modules with high power dissipation are used, the maximum operating temperature range for the device has to be verified.

| Note: Environmental conditions | |
|---|--|
|  | When powering the ABox-93xxLA, make sure the chassis is not covered by any objects. Otherwise the heat dissipation will be restricted by physical effects and the maximum operating temperature will be reduced. |

4.4 Connectors and Interfaces

4.4.1 POWER SUPPLY CONNECTOR

The ABox-93xxLA supports a wide-range voltage input from 16 to 32 V DC.

Power-In connector:

- Connector type: Phoenix MC1,5/2-G-3,5
- Mating connector: e.g. Phoenix FMC1,5/2-ST-3,5

Table 5: Pinout Power-In Connector

| Pin | Signal | Remark |
|-------|---------------|-------------|
| 1 (+) | 16 V to 32 V | Fused @ 5 A |
| 2 (-) | GND / chassis | - |



Figure 1: DC Power Supply Connector

Note: Power requirement



Do not connect or disconnect the Power Supply to the ABox-93xxLA under voltage. Switch off the voltage before plugging.

4.4.2 USB Host Interfaces

The ABox-93xxLA supports two USB Host interfaces.

Double A-Type USB connector for direct usage of USB 2.0 host ports.

4.4.3 Gigabit Ethernet

The ABox-93xxLA supports two Gigabit Ethernet ports (1 x TSN capable, right side).

Table 6: Ethernet LEDs

| LED | Colour / Status | Remark |
|-------------|-----------------|------------------|
| Left (Link) | Off | No link |
| Left (Link) | Green | Link established |
| Right (ACT) | Off | No activity |
| Right (ACT) | Yellow | Activity |



Figure 2: RJ45 Connectors

4.4.4 Power and Reset Button

The Power Button and the Reset Button on the rear side of the ABox-93xxLA. A reset is triggered by Reset Button S2. By default, the PMIC is configured to trigger a cold reset upon activation.

The Power Button S3 offers three reaction possibilities: If it is pressed for more than 5 s, the CPU enters OFF mode. If the button is briefly pushed in OFF mode, the CPU switches back to ON mode. A short push in ON mode triggers an interrupt.

4.4.5 SMA Antenna Connectors

In combination with a M.2 wireless-card, it is possible to add SMA antenna connectors for external antennas. The ABox-93xxLA housing has the holes for up to two SMA connectors as standard.

4.4.6 M.2 Extension Sockets

The ABox-93xxLA provides two M.2 card slots to extend the IOs or other system functionality. The sockets are accessible when the bottom panel is removed.

- 1x M.2 B-Key (USB + SIM Card)
- 1x M.2 E-Key (USB, SDIO, UART)



4.4.7 MicroSD Card Socket

The carrier board in the ABox-93xxLA provides a microSD card socket. The socket is accessible when the back panel is removed.

4.4.8 Reliability and service life

The calculated MTBF of the ABox-93xxLA is approximately TBD @ +40 °C ambient temperature, Ground, Benign.

5. MECHANICS

5.1 Dimensions

The following drawing is a schematic representation of the ABox-93xxLA housing concept.

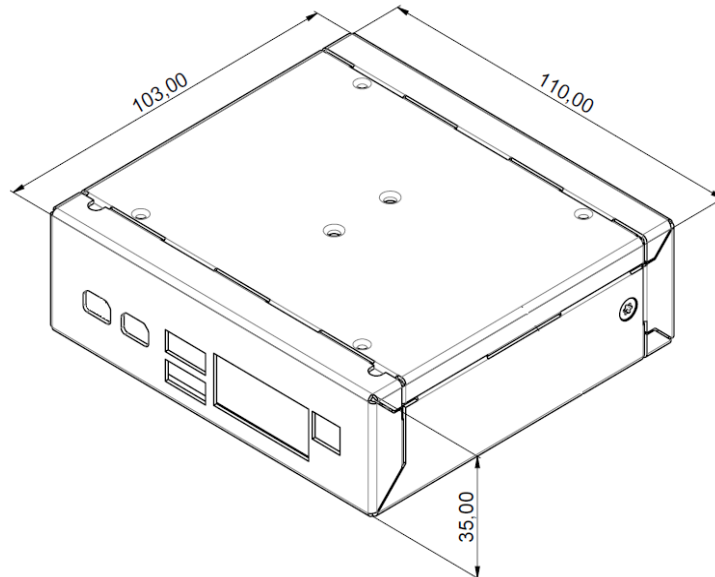

Figure 3: ABox-93xxLA (without connectors), Dimensions (mm), Bottom View

5.2 Mounting

There are several possibilities to mount the ABox-93xxLA:

- With an adapter plate
- To a DIN rail with an optional clamp
- Directly with screws

Please contact support@tq-group.com for more details or ideas suitable for your application.

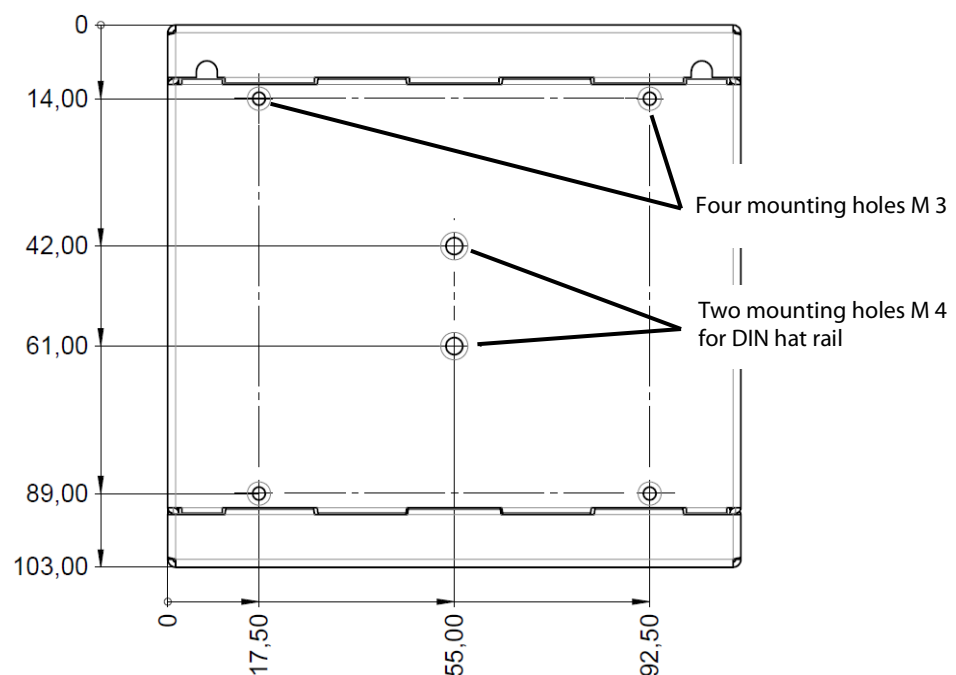

Figure 4: ABox-93xxLA, Dimensions of Mounting Holes (mm), Bottom View



6. REGULATORY INFORMATION

6.1 EU Compliance with Electromagnetic Compatibility Directive EC-Declaration of Conformity

We declare under our sole responsibility that the ABox-93xxLA complies with the essential requirements which are laid down in the referred harmonization measures below:

- Directive 2011/65/EU combined with 2015/863/EU of the European Parliament on the restriction of the use of certain hazardous substances in electrical and electronic equipment
- Directive 2014/30/EU of the European Parliament on the harmonization of the laws of the Member States relating to electromagnetic compatibility.
- Directive 2012/19/EU of the European Parliament on waste electrical and electronic equipment (WEEE)

and complies with the appropriate harmonised standards or specifications:

- EN IEC 63000:2019, Technical documentation for the assessment of electrical and electronic products with respect to the restriction of hazardous substances
- EN 55032:2015, Electromagnetic compatibility of multimedia equipment - Emission Requirements class B.
- EN IEC 61000-6-2:2019, Electromagnetic compatibility – immunity for industrial environments
- IEC 62368-1:2018, Audio/video, information and communication technology equipment – Part 1: Safety requirements

6.2 Cyber Security

A Threat Analysis and Risk Assessment (TARA) must always be performed by the customer for their individual end application, as the ABox-93xxLA is only a sub-component of an overall system.

6.3 Export Control and Sanctions Compliance

The customer is responsible for ensuring that the product purchased from TQ is not subject to any national or international export/import restrictions. If any part of the purchased product or the product itself is subject to said restrictions, the customer must procure the required export/import licenses at its own expense. In the case of breaches of export or import limitations, the customer indemnifies TQ against all liability and accountability in the external relationship, irrespective of the legal grounds. If there is a transgression or violation, the customer will also be held accountable for any losses, damages or fines sustained by TQ. TQ is not liable for any delivery delays due to national or international export restrictions or for the inability to make a delivery as a result of those restrictions. Any compensation or damages will not be provided by TQ in such instances.

The classification according to the European Foreign Trade Regulations (export list number of Reg. No. 2021/821 for dual-use-goods) as well as the classification according to the U.S. Export Administration Regulations in case of US products (ECCN according to the U.S. Commerce Control List) are stated on TQ's invoices or can be requested at any time. Also listed is the Commodity code (HS) in accordance with the current commodity classification for foreign trade statistics as well as the country of origin of the goods requested/ordered.

6.4 Warranty

TQ-Systems GmbH warrants that the product, when used in accordance with the contract, fulfils the respective contractually agreed specifications and functionalities and corresponds to the recognized state of the art.

The warranty is limited to material, manufacturing and processing defects. The manufacturer's liability is void in the following cases:

- Original parts have been replaced by non-original parts.
- Improper installation, commissioning or repairs.
- Improper installation, commissioning or repair due to lack of special equipment.
- Incorrect operation
- Improper handling
- Use of force
- Normal wear and tear

6.5 Statement on California Proposition 65

California Proposition 65, formerly known as the Safe Drinking Water and Toxic Enforcement Act of 1986, was enacted as a ballot initiative in November 1986. The proposition helps protect the state's drinking water sources from contamination by approximately 1,000 chemicals known to cause cancer, birth defects, or other reproductive harm ("Proposition 65 Substances") and requires businesses to inform Californians about exposure to Proposition 65 Substances.



The TQ device or product is not designed or manufactured or distributed as consumer product or for any contact with end-consumers. Consumer products are defined as products intended for a consumer's personal use, consumption, or enjoyment. Therefore, our products or devices are not subject to this regulation and no warning label is required on the assembly.

Individual components of the assembly may contain substances that may require a warning under California Proposition 65. However, it should be noted that the Intended Use of our products will not result in the release of these substances or direct human contact with these substances. Therefore you must take care through your product design that consumers cannot touch the product at all and specify that issue in your own product related documentation.

TQ reserves the right to update and modify this notice as it deems necessary or appropriate.

7. WEEE AND RECYCLING

7.1 WEEE

TQ-Systems GmbH encourages owners to recycle their ABox-93xxLA when it is not used anymore.

The Waste Electrical and Electronic Equipment (WEEE) mark only applies to countries within the European Union (EU) and Norway. Appliances are labelled in accordance with European Directive 2012/19/EU concerning waste electrical and electronic equipment (WEEE). The Directive determines the framework for the return and recycling of used appliances as applicable throughout the European Union.

7.2 Recycling

Users of the ABox-93xxLA must not dispose the ABox-93xxLA as unsorted municipal waste, but use the collection framework available in their country for the return, recycle, or recovery of WEEE and minimize any potential effects on the environment and human health due to the presence of hazardous substances.

ABox-93xxLA must be recycled, mechanically shredded, or incinerated without the battery.



