

TQMx110EB

x86 Family



COM Express® Basic Type 6 Module with 11th Generation Intel® Core™ and Intel® Xeon® W-11000E Series Processors.

Based on

COM Express



HIGHLIGHTS

- ▶ 11th Generation Intel® Core™ i7, Intel® Core™ i5, Intel® Core™ i3 processors
- ▶ Intel® Xeon® W-11000E series processors
- ▶ Desktop / Mobile Workstation performance
- ▶ Up to 8 cores / 16 threads with up to 4.7 GHz turbo and 24 MB Cache
- ▶ New outstanding Intel® Iris® Xe graphics performance with 8K high-resolution outputs
- ▶ Flexible high-speed DDR4-3200 memory configuration with up to 64 GB
- ▶ High-bandwidth extandability through PCIe Gen4 x16 PEG port
- ▶ High-speed peripheral and network interfaces with USB 3.2 Gen2 (10 Gb/s) and 2.5 Gigabit Ethernet
- ▶ For industrial use conditions, with extended temperature option
- ▶ High CPU power efficiency with max. 25 / 35 / 45 W TDP

TECHNICAL SPECIFICATION

CPU	Intel® Core™ i7-11850HE (8-Core, 2.6/4.7 GHz, 24 MB, 32 EU, 35/45 W TDP) Intel® Core™ i5-11500HE (6-Core, 2.6/4.5 GHz, 12 MB, 32 EU, 35/45 W TDP) Intel® Core™ i3-11100HE (4-Core, 2.4/4.4 GHz, 8 MB, 16 EU, 35/45 W TDP) Intel® Xeon® W-11865MRE (8-Core, 2.6/4.7 GHz, 24 MB, 32 EU, ECC, 24/7, RT, eTEMP, 35/45 W TDP) Intel® Xeon® W-11555MRE (6-Core, 2.6/4.5 GHz, 12 MB, 32 EU, ECC, 24/7, RT, eTEMP, 35/45 W TDP) Intel® Xeon® W-11155MRE (4-Core, 2.4/4.4 GHz, 8 MB, 16 EU, ECC, 24/7, RT, eTEMP, 35/45 W TDP) Intel® Xeon® W-11865MLE (8-Core, 1.5/4.5 GHz, 24 MB, 32 EU, ECC, 24/7, RT, 25 W TDP) Intel® Xeon® W-11555MLE (6-Core, 1.9/4.4 GHz, 12 MB, 32 EU, ECC, 24/7, RT, 25 W TDP) Intel® Xeon® W-11155MLE (4-Core, 1.8/3.1 GHz, 8 MB, 16 EU, ECC, 24/7, RT, 25 W TDP)
------------	--

Memory	DDR4-3200: up to 64 GB, 2 SO-DIMMs, ECC (option) Onboard soldered NVMe SSD (PCIe Gen3 x4) up to 1 TB (option) EEPROM: 32 kbit (24AA32) (option)
---------------	---

Graphics	Up to 4 independant display outputs: 3x DP/DP++ 1.4a with up to 8K; MST-Support 1x eDP 1.4b or dual channel LVDS interface
-----------------	--

Additional components and controller	1x TPM 2.0 (SLM9670) (opt.) / firmware TPM TQMx86 board controller (WD and TQ-flexiCFG) Hardware monitor for thermal mamangement
---	--

Interfaces	1x 2.5 Gigabit Ethernet (Intel® i225) 4x USB 3.2 Gen2 (up to 10 Gb/s) with USB 3.0 compatibility 8x USB 2.0 1x PEG-Port with PCIe Gen4 (up to 16 Gb/s per lane) (1x16, 2x8 or 2x4+1x8) 8x PCIe Gen3 (up to 8 Gb/s) (8x1, 4x2 or 2x4) 4x SATA Gen3 (up to 6 Gb/s) 1x LPC or eSPI 1x I2C (master/slave capable), 2nd port opt. 1x SMBus 1x SPI (for external UEFI BIOS flash) 2x UART (Rx/Tx) (4-wire optional) 8x GPIO through TQ flexiCFG
-------------------	--

Power supply	Volatge: 14.5 V – 20 V, 5 V Standby (opt.), 3 V battery Power: typ. 30...50 W / max. 200 W (preliminary)
---------------------	---

Environment	Standard temperature: 0°C...+60°C Extended temperature: -40°C...+60°C
--------------------	--

Form factor/ dimensions	COM Express® Basic, Type 6 125 mm x 95 mm
--------------------------------	--

BLOCK DIAGRAM TQMX110EB

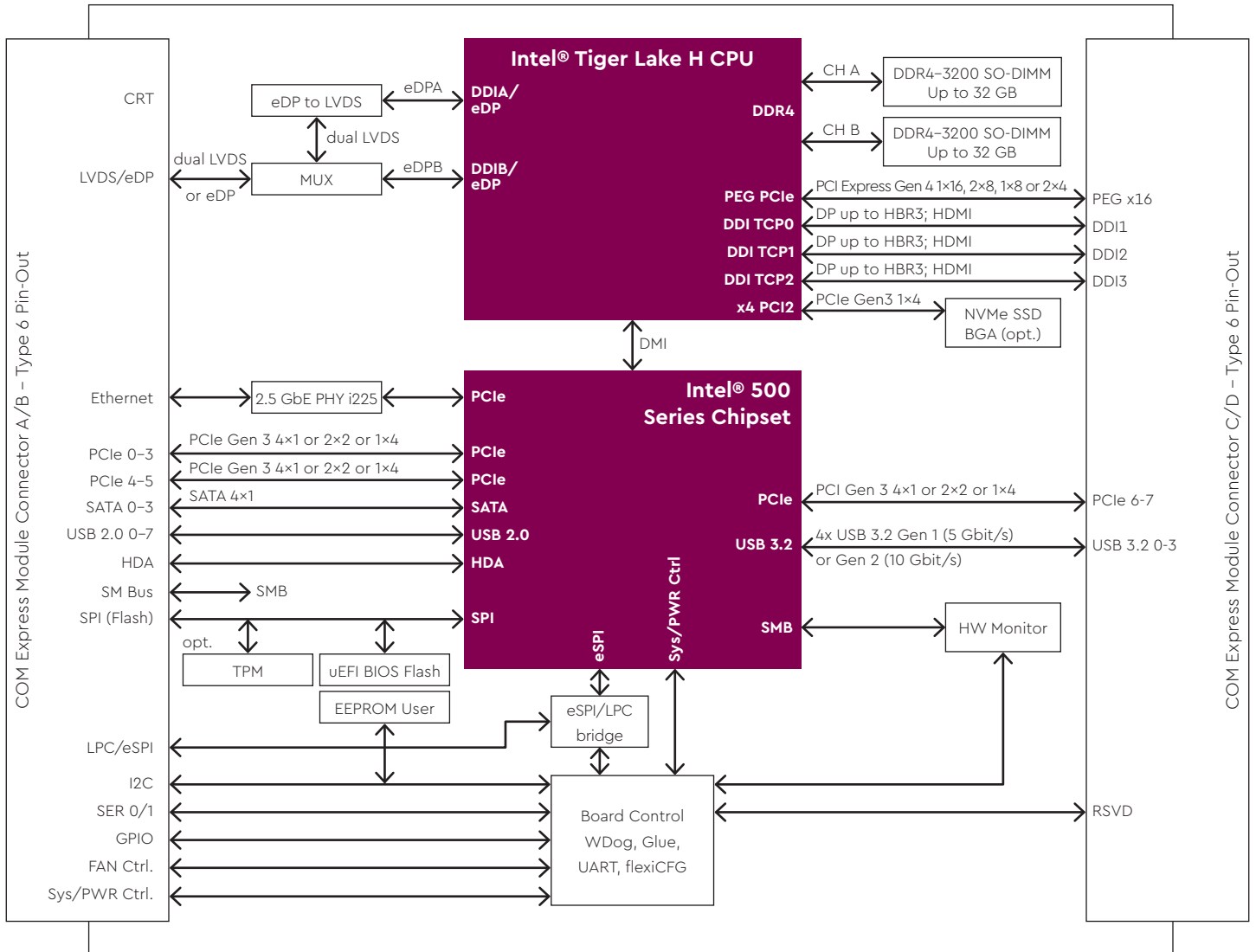

ORDERING INFORMATION

- TQMX110EB-AA** Intel® Core™ i7-11850HE, HM570E, no onboard SSD, TPM 2.0, C-Temp
- TQMX110EB-AB** Intel® Core™ i5-11500HE, HM570E, no onboard SSD, TPM 2.0, C-Temp
- TQMX110EB-AC** Intel® Core™ i3-11100HE, HM570E, no onboard SSD, TPM 2.0, C-Temp
- TQMX110EB-AD** Intel® Xeon® W-11865MRE, RM590E, DDR4-ECC-Support, no onboard SSD, TPM 2.0, industrial use conditions, I-Temp
- TQMX110EB-AE** Intel® Xeon® W-11555MRE, RM590E, DDR4-ECC-Support, no onboard SSD, TPM 2.0, industrial use conditions, I-Temp
- TQMX110EB-AF** Intel® Xeon® W-11155MRE, RM590E, DDR4-ECC-Support, no onboard SSD, TPM 2.0, industrial use conditions, I-Temp
- TQMX110EB-AG** Intel® Xeon® W-11865MLE, RM590E, DDR4-ECC-Support, no onboard SSD, TPM 2.0, industrial use conditions, C-Temp
- TQMX110EB-AH** Intel® Xeon® W-11555MLE, RM590E, DDR4-ECC-Support, no onboard SSD, TPM 2.0, industrial use conditions, C-Temp
- TQMX110EB-AI** Intel® Xeon® W-11155MLE, RM590E, DDR4-ECC-Support, no onboard SSD, TPM 2.0, industrial use conditions, C-Temp

Other configurations on request

TQ-Systems GmbH

Mühlstraße 2 | Gut Delling | 82229 Seefeld | Germany
 Tel.: +49 8153 9308-0 | info@tq-group.com | tq-group.com

tq-embedded.com