



STK-MBa35 User's Manual

STK-MBa35 UM 101
01.08.2011

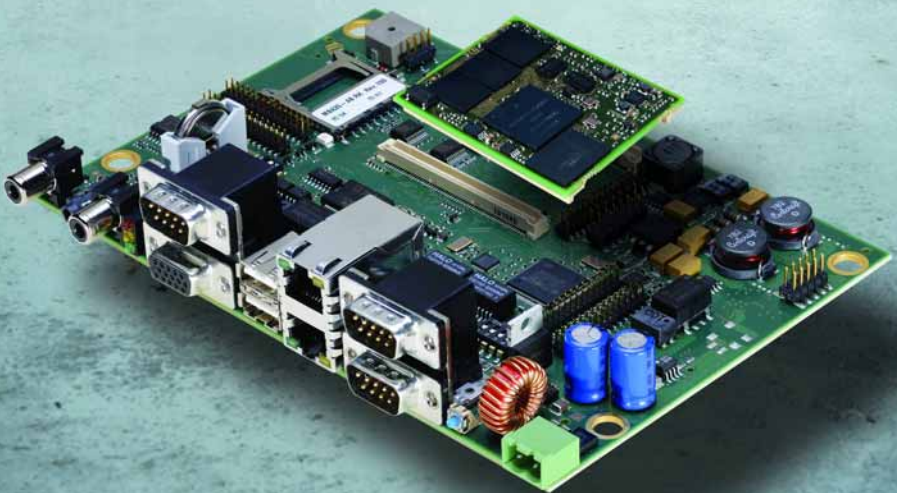

Table of contents

1.	ABOUT THIS MANUAL.....	1
1.1	Copyright.....	1
1.2	Tips on safety.....	1
1.3	Symbols and Typographic Conventions.....	1
1.4	Handling and ESD tips.....	2
1.5	Registered trademarks.....	2
1.6	Imprint.....	3
1.7	Disclaimer.....	3
1.8	Copyright and licence expenses.....	3
1.9	Further applicable documents / presumed knowledge.....	4
1.10	Acronyms and definitions.....	5
2.	BRIEF DESCRIPTION.....	7
3.	TECHNICAL DATA.....	7
3.1	System architecture and system functionality.....	7
3.1.1	Block diagram.....	7
3.1.2	System functionality.....	7
3.1.2.1	External interfaces.....	8
3.1.2.2	Internal interfaces.....	8
3.1.2.3	User's interfaces.....	8
3.1.2.4	System components.....	8
3.1.3	Technical data mechanics, design.....	8
4.	ELECTRONICS SPECIFICATION.....	9
4.1	External interfaces.....	9
4.1.1	Function specification.....	9
4.1.1.1	Ethernet 1 (X26B).....	9
4.1.1.2	Ethernet 2 (X26A).....	10
4.1.1.3	RS485 (X32A).....	10
4.1.1.4	RS232 (X32B).....	11
4.1.1.5	CAN 1 / CAN 2 (X1A).....	12
4.1.1.6	GPIO (X1B).....	13
4.1.1.7	USB 2.0 Hi-Speed Host (X12-A).....	14
4.1.1.8	USB 2.0 Hi-Speed OTG (X12-B).....	15
4.1.1.9	Audio-output right (X27) and left (X28), microphone input (X13).....	15
4.1.1.10	Buzzer (N10).....	16
4.1.1.11	SD card (X4).....	16
4.1.1.12	Power-IN (X6).....	16



Table of contents

4.1.2	Electrical characteristics	17
4.1.2.1	Ethernet 1 (X26B).....	17
4.1.2.2	Ethernet 2 (X26A)	17
4.1.2.3	USB 2.0 Hi-Speed Host (X12-A)	17
4.1.2.4	USB 2.0 Hi-Speed OTG (X12-B)	17
4.1.2.5	RS485 (X32A)	17
4.1.2.6	RS232 (X32B).....	17
4.1.2.7	CAN 1/ CAN 2 (X1A).....	18
4.1.2.8	GPIO (X1B)	18
4.1.2.9	SD card (X4).....	18
4.1.2.10	Audio-output right (X27) and left (X28)	19
4.1.2.11	Microphone input (X13).....	19
4.1.2.12	Power-IN (X6).....	19
4.1.3	Plug connectors and pin assignments.....	20
4.1.3.1	Ethernet 1 (X26B).....	20
4.1.3.2	Ethernet 2 (X26A)	22
4.1.3.3	RS485 (X32A)	23
4.1.3.4	RS232 (X32B).....	24
4.1.3.5	CAN 1/ CAN 2 (X1A)	25
4.1.3.6	GPIO (X1B)	26
4.1.3.7	USB 2.0 Hi-Speed Host (X12-A)	27
4.1.3.8	USB 2.0 Hi-Speed OTG (X12-B)	28
4.1.3.9	Audio-output right (X27) and left (X28)	29
4.1.3.10	Microphone input (X13).....	30
4.1.3.11	SD card (X4).....	31
4.1.3.12	Power-IN (X6).....	32
4.2	Internal interfaces	33
4.2.1	Function specification	35
4.2.1.1	Module interface (D10).....	35
4.2.1.2	JTAG (X16)	35
4.2.1.3	LCD (X22, X23).....	35
4.2.1.4	LCD backlight (X21, X24, X5).....	36
4.2.1.5	Touchscreen (X2, X8).....	36
4.2.1.6	LVDS Display (X9)	37
4.2.1.7	SD card (X25)	38
4.2.1.8	Power-On (X19).....	38
4.2.1.9	Starterkit interfaces (X7, X10, X14, X15, X18, X31).....	39

Table of contents

4.2.2	Electrical characteristics	39
4.2.2.1	LCD (X22, X23)	39
4.2.2.2	LCD backlight (X21, X24, X5)	39
4.2.2.2.1	LED driver (X21, X24)	39
4.2.2.2.2	Backlight power supply (X5)	39
4.2.2.3	Touchscreen (X2, X8)	40
4.2.2.4	LVDS Display (X9)	40
4.2.2.5	SD card (X25)	40
4.2.2.6	Starterkit interfaces (X7, X10, X14, X15, X18, X31)	40
4.2.3	Plug connector and pins assignment	41
4.2.3.1	Module interface (D10)	41
4.2.3.2	JTAG (X16)	45
4.2.3.3	LCD (X22, X23)	46
4.2.3.4	LCD backlight (X21, X24, X5)	48
4.2.3.5	Touchscreen (X2, X8)	49
4.2.3.6	LVDS Display (X9)	50
4.2.3.7	SD card (X25)	51
4.2.3.8	Power-On (X19)	52
4.2.3.9	Starterkit interfaces (X7, X10, X14, X15, X18, X31)	52
4.2.3.9.1	Starterkit interface (X7)	53
4.2.3.9.2	Starterkit interface (X10)	54
4.2.3.9.3	Starterkit interface (X14)	55
4.2.3.9.4	Starterkit interface (X15)	56
4.2.3.9.5	Starterkit interface (X18)	57
4.2.3.9.6	Starterkit interface (X31)	58
4.3	User's interfaces	59
4.3.1	Reset button (S2)	59
4.3.2	Status-LEDs external (V77)	59
4.3.3	Status-LEDs internal (V22, V24, V25, V46, V78)	60
4.3.4	DIP switch (S1, S3)	60
4.4	System components	61
4.4.1	Temperature sensor (D22)	61
4.4.2	I ² C address allocation	61
4.4.3	Battery	61



Table of contents

5.	SOFTWARE SPECIFICATION	61
6.	MECHANICS SPECIFICATION	62
6.1	Construction	62
6.1.1	PCB outlines STK-MBa35	62
6.1.2	STK-MBa35 top view	63
6.1.3	STK-MBa35 bottom view	64
7.	REQUIREMENTS FOR THE SUPERIOR SYSTEM	65
7.1	Protection against external effects	65
7.2	Thermal management	65
8.	SAFETY REQUIREMENTS AND PROTECTIVE REGULATIONS	66
8.1	EMC characteristics	66
8.2	Operational safety and personal security	66
9.	CLIMATIC AND OPERATIONAL CONDITIONS	67
9.1	Protection against external effects	67
9.2	Reliability and product life	67
9.3	The used displays	67
9.4	Batteries	67
9.4.1	General notes	67
9.4.2	Lithium battery	67
9.5	Environment protection	68
9.6	RoHS compliance	68
9.7	WEEE regulation	68

Table directory

Table 1:	Terms and conventions.....	1
Table 2:	Acronyms.....	5
Table 3:	Allocation of the GPIOs.....	14
Table 4:	Electrical characteristics of the GPIOs	18
Table 5:	Electrical characteristics of the GPOs	18
Table 6:	Electrical characteristics of the power supply	19
Table 7:	Overview of the function groups of the power supply	19
Table 8:	Plug connector Ethernet 1 (X26B).....	20
Table 9:	Pin assignment plug connector Ethernet 1 (X26B).....	20
Table 10:	Status LEDs Ethernet 1.....	21
Table 11:	Plug connector Ethernet 2 (X26A).....	22
Table 12:	Pin assignment plug connector Ethernet 2 (X26A)	22
Table 13:	Plug connector RS485 (X32A).....	23
Table 14:	Pin assignment plug connector RS485 (X32A).....	23
Table 15:	Plug connector RS232 (X32B).....	24
Table 16:	Pin assignment plug connector RS232 (X32B)	24
Table 17:	Plug connector CAN 1 and CAN 2 (X1A).....	25
Table 18:	Pin assignment plug connector CAN 1 and CAN 2 (X1A)	25
Table 19:	Plug connector GPIO (X1B).....	26
Table 20:	Pin assignment plug connector GPIO (X1B).....	26
Table 21:	Plug connector USB Host (X12-A)	27
Table 22:	Pin assignment plug connector USB Host (X12-A)	27
Table 23:	Plug connector USB OTG (X12-B)	28
Table 24:	Pin assignment plug connector USB OTG (X12-B)	28
Table 25:	Plug connector audio output right (X27) and left (X28).....	29
Table 26:	Pin assignment plug connector audio output right (X27) and left (X28).....	29
Table 27:	Plug connector microphone (X13).....	30
Table 28:	Pin assignment plug connector microphone (X13).....	30
Table 29:	Plug connector external SD card (X4)	31
Table 30:	Pin assignment plug connector external SD card (X4)	31
Table 31:	Plug connector Power-IN (X6).....	32
Table 32:	Pin assignment plug connector Power-IN (X6).....	32
Table 33:	Allocation of RGB signals on LVDS lines.....	37
Table 34:	Plug connector module interface (D10).....	41
Table 35:	Pin assignment module plug connector (D10-X1)	42
Table 36:	Pin assignment module plug connector (D10-X2)	43
Table 37:	Pin assignment module plug connector (D10-X3)	44

Table directory

Table 38:	Plug connector JTAG (X16).....	45
Table 39:	Pin assignment plug connector JTAG (X16).....	45
Table 40:	Plug connector LCD (X22, X23)	46
Table 41:	Pin assignment plug connector LCD (X22, X23)	46
Table 42:	Plug connector LCD backlight (X21, X24)	48
Table 43:	Pin assignment plug connector LCD backlight (X21, X24).....	48
Table 44:	Plug connector LCD backlight (X5).....	48
Table 45:	Pin assignment plug connector LCD backlight (X5).....	48
Table 46:	Plug connector touchscreen (X2).....	49
Table 47:	Plug connector touchscreen (X8).....	49
Table 48:	Pin assignment plug connector touchscreen (X2, X8).....	49
Table 49:	Plug connector LVDS Display (X9)	50
Table 50:	Pin assignment plug connector LVDS Display (X9)	50
Table 51:	Plug connector internal SD card (X25).....	51
Table 52:	Pin assignment plug connector internal SD card (X25)	51
Table 53:	Plug connector Power-On (X19).....	52
Table 54:	Pin assignment plug connector touchscreen (X2, X8).....	52
Table 55:	Plug connector Starterkit interface (X7)	53
Table 56:	Plug connector pin assignment Starterkit interface (X7)	53
Table 57:	Plug connector Starterkit interface (X10).....	54
Table 58:	Plug connector pin assignment Starterkit interface (X10)	54
Table 59:	Plug connector Starterkit interface (X14).....	55
Table 60:	Plug connector pin assignment Starterkit interface (X14)	55
Table 61:	Plug connector Starterkit interface (X15).....	56
Table 62:	Plug connector pin assignment Starterkit interface (X15)	56
Table 63:	Plug connector Starterkit interface (X18).....	57
Table 64:	Plug connector pin assignment Starterkit interface (X18)	57
Table 65:	Plug connector Starterkit interface (X31).....	58
Table 66:	Plug connector pin assignment Starterkit interface (X31)	58
Table 67:	Reset button (S2)	59
Table 68:	External Status-LEDs (V77).....	59
Table 69:	Overview external LEDs.....	59
Table 70:	Overview internal LEDs	60
Table 71:	DIP switch S1	60
Table 72:	DIP switch S3	60
Table 73:	I ² C address allocation.....	61
Table 74:	Component selection battery RTC.....	61

Illustration directory

Illustration 1:	Block diagram STK-MBa35	7
Illustration 2:	External interfaces of the STK-MBa35	9
Illustration 3:	Block diagram Ethernet 1	9
Illustration 4:	Block diagram Ethernet 2	10
Illustration 5:	Block diagram RS485	10
Illustration 6:	Block diagram RS232	11
Illustration 7:	Block diagram CAN.....	12
Illustration 8:	Block diagram GPIO	13
Illustration 9:	Block diagram USB Host	14
Illustration 10:	Block diagram USB OTG.....	15
Illustration 11:	Block diagram audio	15
Illustration 12:	Block diagram buzzer	16
Illustration 13:	Block diagram external SD card	16
Illustration 14:	Block diagram Power-IN	16
Illustration 15:	Wiring of X26B	21
Illustration 16:	Wiring of X32A.....	23
Illustration 17:	Wiring of X32B	24
Illustration 18:	Wiring of X1A	25
Illustration 19:	Wiring of X1B.....	26
Illustration 20:	Wiring of X12-A	27
Illustration 21:	Wiring of X12-B.....	28
Illustration 22:	Wiring of X27 / X28.....	29
Illustration 23:	Wiring of X13.....	30
Illustration 24:	Wiring of X4	31
Illustration 25:	Wiring of X6	32
Illustration 26:	Component placement top.....	33
Illustration 27:	Component placement bottom	34
Illustration 28:	Block diagram LCD	35
Illustration 29:	Block diagram LCD backlight.....	36
Illustration 30:	Block diagram touchscreen	36
Illustration 31:	Block diagram LVDS Display.....	37
Illustration 32:	Block diagram internal SD card	38
Illustration 33:	Block diagram Power-On.....	38
Illustration 34:	Wiring of D10	41
Illustration 35:	Wiring of X21, X24	48
Illustration 36:	Wiring of X25.....	51
Illustration 37:	Block diagram LED.....	59
Illustration 38:	PCB outlines STK-MBa35.....	62
Illustration 39:	Top view	63
Illustration 40:	Bottom view	64



Revision history

Rev.:	Date:	Name:	Pos.:	Modification:
100	14.04.2011	Petz		Document created
101	01.08.2011	Petz	Illustration 2 Table 39 7.1.1 7.1.2 8.1.1 8.1.2	Replaced Remarks corrected 7.1 7.2 8.1 8.2 Typo

1. ABOUT THIS MANUAL

1.1 Copyright

Copyright protected © 2011 by TQ-Components GmbH.





This User's Manual may not be copied, reproduced, translated, changed or distributed, completely or partially in electronic, machine readable, or in any other form without the written consent of TQ-Components GmbH.

1.2 Tips on safety

Improper or incorrect handling of the product can substantially reduce its life span.

1.3 Symbols and Typographic Conventions

Table 1: Terms and conventions

Symbol / Visual Cue	Meaning
	This symbol represents the handling of electrostatic-sensitive modules and / or components. These components are often damaged / destroyed by the transmission of a voltage higher than about 50 V. A human body usually only experiences electrostatic discharges above approximately 3,000 V.
	This symbol indicates the possible use of voltages higher than 24 V. Please note the relevant statutory regulations in this regard. Non-compliance with these regulations can lead to serious damage to your health and also cause damage / destruction of the component.
	This symbol indicates a possible source of danger. Acting against the procedure described can lead to possible damage to your health and / or cause damage / destruction of the material used.
	This symbol represents important details or aspects for working with TQ-products.
Command	A font with fixed-width is used to denote commands, file names, or menu items.

1.4 Handling and ESD tips

General handling of your TQ-products

	<p>The TQ-product may only be used and serviced by certified personnel who have taken note of the information, the safety regulations in this document and all related rules and regulations.</p> <p>A general rule is: do not touch the TQ-product during operation. This is especially important when switching on, changing jumper settings or connecting other devices without ensuring beforehand that the power supply of the system has been switched off.</p> <p>Violation of this guideline may result in damage / destruction of the module and be dangerous to your health.</p> <p>Improper handling of your TQ-product would render the guarantee invalid.</p>
---	--

Proper ESD handling

	<p>The electronic components of your TQ-product are sensitive to electrostatic discharge (ESD).</p> <p>Always wear antistatic clothing, use ESD-safe tools, packing materials etc., and operate your TQ-product in an ESD-safe environment. Especially when you switch modules on, change jumper settings, or connect other devices.</p>
---	--

1.5 Registered trademarks

TQ-Components GmbH aims to adhere to the copyrights of all the used graphics and texts in all publications and strives to use original or license-free graphics and texts. All the brand names and trademarks mentioned in the publication, including those protected by a third party, unless specified otherwise in writing, are subjected to the specifications of the current copyright laws and the proprietary laws of the present registered proprietor without any limitation. One should conclude that brands and trademarks are protected through the rights of a third party.

1.6 Imprint

TQ-Components GmbH
Gut Delling, Mühlstraße 2
82229 Seefeld
Tel: +49 (0)8153 9308-0
Fax: +49 (0)8153 9308-134
Email: info@tqc.de
Web: <http://www.tq-group.com/>

1.7 Disclaimer

TQ-Components GmbH does not guarantee that the information in this manual is up-to-date, correct, complete or of good quality. Nor does TQ-Components assume guarantee for further usage of the information. Liability claims against TQ-Components GmbH, referring to material or non-material related damages, caused due to usage or non-usage of the information given in the manual, or caused due to usage of erroneous or incomplete information, are exempted, as long as there is no proven, intentional or negligent fault of TQ-Components GmbH. TQ-Components GmbH explicitly reserves the rights to change or add to the contents of this manual or parts of it without special notification.

1.8 Copyright and licence expenses

The drivers and utilities for the used components as well as the BIOS are subject to the copyrights of the respective manufacturers. The licence conditions of the respective manufacturer are to be adhered to.

Bootloader-licence expenses are paid by TQ and are included in the price.

Licence expenses for the operating system and applications are not taken into consideration and must be separately calculated / declared.



1.9 Further applicable documents / presumed knowledge

- **Specifications and manual of the used modules:**
These documents describe the service, functionality and special characteristics of the used module (incl. BIOS).
- **Specifications of the used components:**
The manufacturer's specifications of the used components, for example Compact-Flash cards, are to be taken note of. They contain, if applicable, additional information that must be taken note of for safe and reliable operation. These documents are stored at TQ.
- **Chip errata:**
It is the user's responsibility to make sure all errata published by the manufacturer of each component are taken note of. The manufacturer's advice should be followed.
- **Software behaviour:**
No warranty can be given, nor responsibility taken for any unexpected software behaviour due to deficient components.
- **General expertise:**
Expertise in electrical engineering / computer engineering is required for the installation and the use of the device.

1.10 Acronyms and definitions

The following acronyms and abbreviations are used in this document:

Table 2: Acronyms

Acronym	Meaning
AC	Alternating Current
AGND	Analog Ground
ARM®	Advanced RISC Machine
CAN	Controller Area Network
CPU	Central Processing Unit
DC	Direct Current
DCE	Data Communication Equipment (e.g. modem)
DGND	Digital Ground
DIN	Deutsche Industrie Norm
DIP	Dual In-line Package
DTE	Data Terminal Equipment (e.g. PC)
EEPROM	Electrically Erasable Programmable Read-only Memory
EMC	Electromagnetic Compatibility
EMMC	embedded MultiMediaCard (Flash)
EN	Europäische Norm (European Standards)
FET	Field Effect Transistor
FFC	Flat Flex Cable
FPC	Flexible Printed Circuit
FR-4	Flame Retardant-4
GND	Ground
GPI	General Purpose Input
GPIO	General Purpose Input/Output
GPO	General Purpose Output
HD-D-sub	High Density D-sub
I/O	Input/Output
I/P	Input/Power
IEEE	Institute of Electrical and Electronics Engineers
IP00	Ingress Protection 00
I ² C	Inter-Integrated Circuit
JTAG	Joint Test Action Group
LCD	Liquid Crystal Display

Acronym	Meaning
LED	Light Emitting Diode
LVDS	Low Voltage Differential Signal
MIC	Microphone
MII	Media-Independent Interface
MMC	Multimedia Card
MOZI	Module extractor (Modulzieher)
NC	Not Connected
OTG	On-The-Go
PCB	Printed Circuit Board
PHY	Physical (Interface)
PMIC	Power Management IC
PWM	Pulse Width Modulation
RAM	Random Access Memory
RCA	Radio Corporation of America
RFU	Reserved for Future Use
RGB	Red Green Blue
RJ	Registered Jack
RoHS	Restriction of (the use of certain) Hazardous Substances
RS232	Recommended Standard (serial interface)
RTC	Real-Time Clock
SD	Secure Digital
SDHC	Secure Digital High Capacity
SPI	Serial Peripheral Interface
SPS	Speicherprogrammierbare Steuerung ⇒ Programmable Logic Controller (PLC)
THD+N	Total Harmonic Distortion + Noise
UART	Universal Asynchronous Receiver/Transmitter
UN	United Nations
USB	Universal Serial Bus
VGA	Video Graphics Array (640 × 480)
WEEE	Waste Electrical and Electronic Equipment
WEIM	Wireless External Interface Module
WP	Write-Protection

2. BRIEF DESCRIPTION

The STK-MBa35 is designed to be driven by TQ modules based on the Freescale ARM CPU MCIMX35 (i.MX35). In combination with a module and a display with touchscreen it offers PC core functionalities and standard interfaces.

By using the functionalities of the Starterkit STK-MBa35 this main board forms together with the TQMa35 a modular system to develop own product ideas.

3. TECHNICAL DATA

3.1 System architecture and system functionality

3.1.1 Block diagram

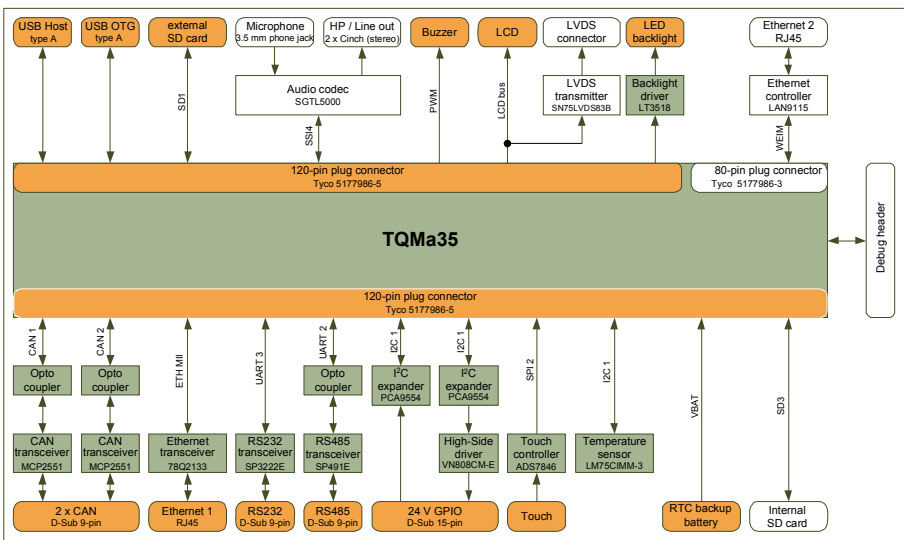

Illustration 1: Block diagram STK-MBa35

3.1.2 System functionality

The interfaces and system components listed in the following are implemented on the STK-MBa35. Due to the fact that the STK-MBa35 can be installed in a casing the interfaces are divided into external and internal interfaces.



3.1.2.1 External interfaces

- 2 × Ethernet 10/100 Mbit
- 1 × RS485
- 1 × RS232
- 2 × CAN
- 1 × USB 2.0 Hi Speed Host interface
- 1 × USB 2.0 Hi Speed On-The-Go device interface
- 1 × GPIO (8 × OUT / 4 × IN)
- 1 × SD card
- 2 × Audio output
- 1 × Microphone input
- 1 × Power supply

3.1.2.2 Internal interfaces

- 1 × TQMa35
- 1 × JTAG
- 2 × LCD (model dependent)
- 2 × LCD backlight (model dependent)
- 2 × Touchscreen (model dependent)
- 1 × LCD via LVDS (optional)
- 1 × SD card (optional)
- 1 × Power-On button
- 5 × headers and 1 × power supply (Starterkit function / optional)

3.1.2.3 User's interfaces

- 1 × Reset button
- 3 × Status LEDs (external)
- 5 × Status LEDs (internal)
- 2 × DIP switch

3.1.2.4 System components

- Backup battery
- Buzzer
- Temperature sensor
- Power supply
- Voltage supervision and reset concept

3.1.3 Technical data mechanics, design

Dimensions PCB (W × D × H):	175 × 120 × 2 mm ³
Overall dimensions (W × D × H):	175 × 130 × 32 mm ³ (app.)
Weight:	261 g

4. ELECTRONICS SPECIFICATION

4.1 External interfaces

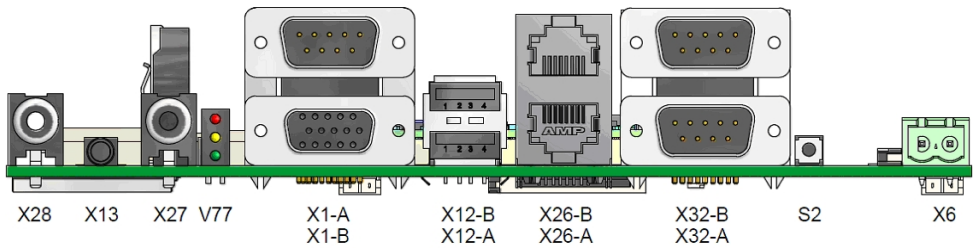

Illustration 2: External interfaces of the STK-MBa35

4.1.1 Function specification

4.1.1.1 Ethernet 1 (X26B)

The MII interface of the TQMa35 drives the Ethernet 1 interface. The Teridian78Q2133 is used as PHY.

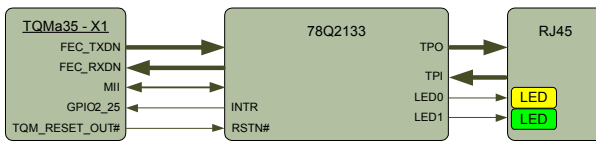

Illustration 3: Block diagram Ethernet 1

LED configuration see Table 9 on page 20.

Further LED configurations are programmable.

4.1.1.2 Ethernet 2 (X26A)

The Ethernet 2 interface is implemented by using the SMSC WEIM-PHY LAN9115. This interface is only available if the TQMa35 is equipped with plug connector X3.

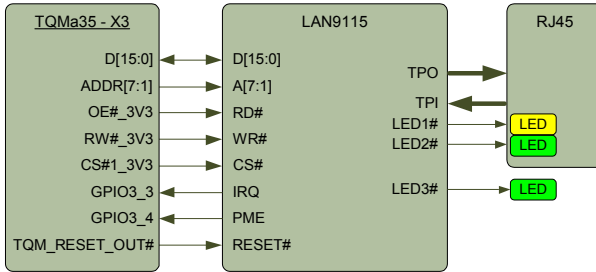

Illustration 4: Block diagram Ethernet 2

LED configuration see Table 12 on page 22.

4.1.1.3 RS485 (X32A)

The UART2 of the TQMa35 drives the RS485 interface of the STK-MBa35. The optocouplers Avago HCPL0631 and HCPL0601 are used for galvanic separation. The Recom RSS-0505/HP serves as the power supply for the galvanically separated part of the RS485 interface.

The Exar SP491EEN-L is used as RS485 transceiver.

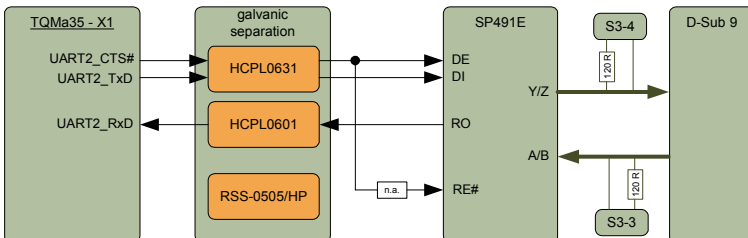

Illustration 5: Block diagram RS485

The RS485 signals can be terminated with 120 Ω with either DIP switch S3 or cable-sided by bridging pins 8 / 9 (RxD) and 1 / 7 (TxD). Details can be found in Table 72 on page 60.

4.1.1.4 RS232 (X32B)

The UART3 interface of the TQMa35 drives the RS232 interface of the STK-MBa35 by default. The Exar SP3222EEA-L is used as a driver. The RS232 interface driver on the TQMa35 can be used as an alternative. This uses UART1 of the TQMa35. It is however not recommended due to EMC reasons.

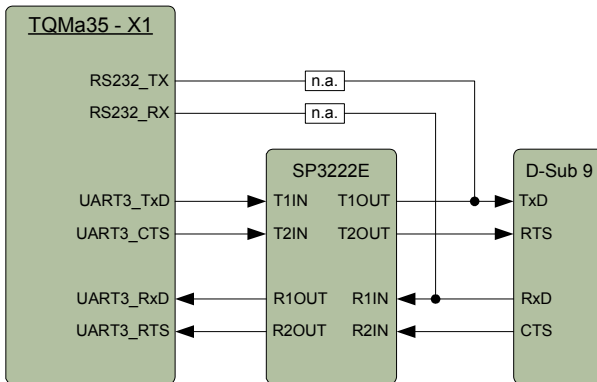

Illustration 6: Block diagram RS232

The CPU i.MX35 on the TQMa35 is designed as data communication equipment (DCE). The signals RTS and CTS do therefore not behave as in data terminal equipment (DTE, e.g., PC). The signal UART3_RTS of the TQMa35 is an input, the signal UART3_CTS of the TQMa35 is an output.

To compensate for this behaviour of the i.MX35, the signals RTS and CTS are crossed on the STK-MBa35:

- the CTS signal coming from an external source via (X32_8B) is routed as signal UART3_RTS on the STK-MBa35 to pin X1_108 of the TQMa35
- the RTS signal going to an external receiver via (X32_7B) comes as signal UART3_CTS on the STK-MBa35 from pin X1_109 of the TQMa35

4.1.1.5 CAN 1 / CAN 2 (X1A)

The two CAN ports of the TQMa35 directly drive both CAN interfaces on the STK-MBa35. Optocouplers of type Avago HCPL0601 are used for galvanic separation. The Recom RTS-0505/P serves as the power supply for the galvanically separated part of the CAN interface. Microchip MCP2551T-I/SN are used as CAN transceivers.

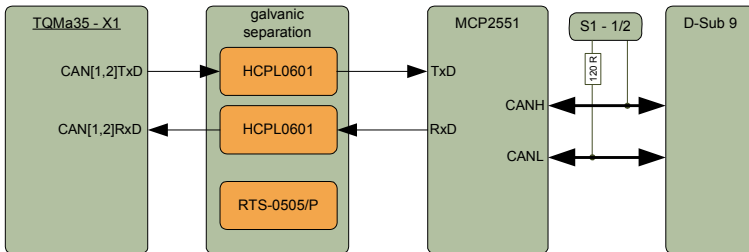

Illustration 7: Block diagram CAN

The CAN signals can be terminated with 120 Ω by using DIP switch S1 (see Table 71 on page 60).

4.1.1.6 GPIO (X1B)

Eight GPIO outputs and four GPIO inputs are made available at an external plug connector. A voltage of $24\text{ V} \pm 20\%$ at the GPIO plug connector serves as the power supply. Due to the placement option the supply voltage of the STK-MBa35 can alternatively be used as the power supply. In this case the user has to ensure the correct level of the input voltage.

Two NXP (PCA9554D) 8 bit I²C bus I/O port circuits generate the GPIOs. This circuit offers eight bidirectional GPIO ports, which can drive and sink 10 mA.

The I²C addresses of both I²C I/O ports are listed in section 4.4.1 on page 61.

The basic circuit of the GPIO connection on the STK-MBa35 is shown in Illustration 8. The remaining four I/O ports are used for two user-LEDs (yellow and red) at V77, to switch on the backlight via plug connector X5 and to switch on the LVDS transmitter (LVDS Display).

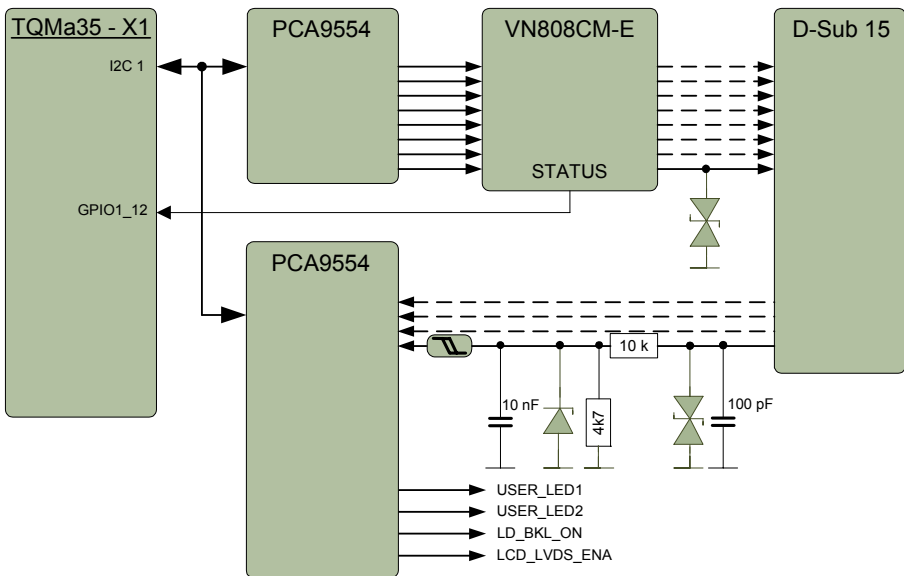

Illustration 8: Block diagram GPIO

Table 3: Allocation of the GPIOs

Signal	I ² C base address	I/O port	Direction
GPO1	0x20	IO0	O
GPO2		IO1	O
GPO3		IO2	O
GPO4		IO3	O
GPO5		IO4	O
GPO6		IO5	O
GPO7		IO6	O
GPO8		IO7	O
GPI1	0x21	IO0	I
GPI2		IO1	I
GPI3		IO2	I
GPI4		IO3	I
USER_LED1		IO4	O
USER_LED2		IO5	O
LD_BKL_ON		IO6	O
LCD_LVDS-ENA		IO7	O

4.1.1.7 USB 2.0 Hi-Speed Host (X12-A)

The USB host interface of the TQMa35 is routed directly to the USB-A jack X12-A, including the protection circuit. The over-current protection is implemented with a Texas Instruments TPS2042B.

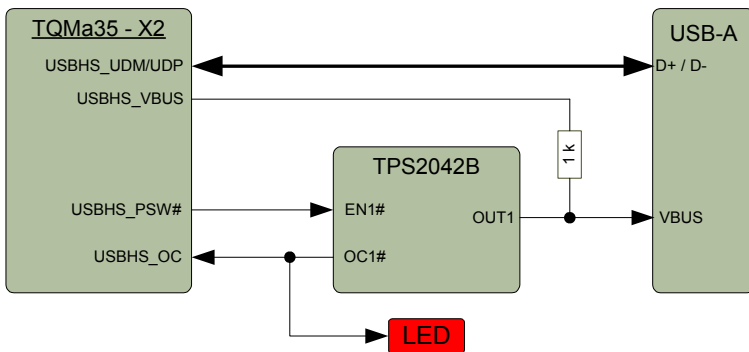

Illustration 9: Block diagram USB Host

4.1.1.8 USB 2.0 Hi-Speed OTG (X12-B)

The USB OTG interface is configured as the host by default and cannot be connected to a PC as device.

To offer OTG functionality it is possible to provide a USB-Mini-AB jack or Mini-B by a placement option.

However, as a result the USB 2.0 Hi Speed interface falls away.

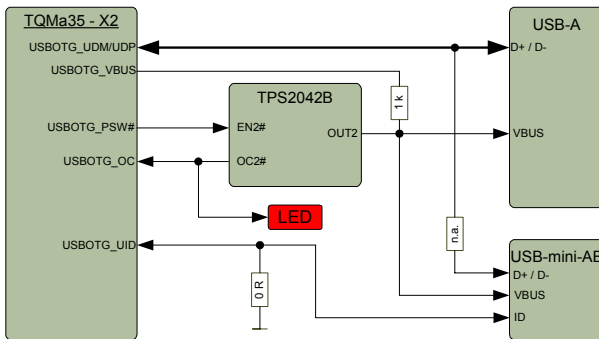

Illustration 10: Block diagram USB OTG

4.1.1.9 Audio-output right (X27) and left (X28), microphone input (X13)

The audio-functionality is implemented with a Freescale SGTL5000 on the STK-MBa35.

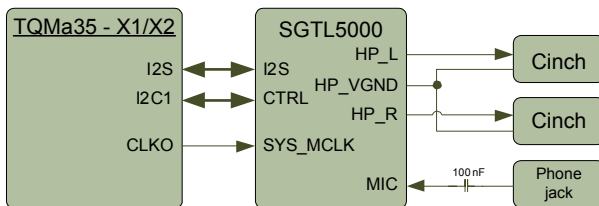

Illustration 11: Block diagram audio

The SGTL5000 can be accessed via I²C base address 0x0A.

4.1.1.10 Buzzer (N10)

The PWM output of the TQMa35 controls the buzzer.

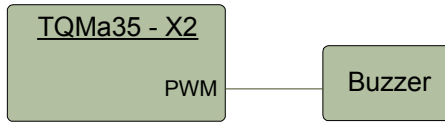

Illustration 12: Block diagram buzzer

4.1.1.11 SD card (X4)

The external SD card is connected to the SD1 bus of the TQMa35. Card-Detect and Write-Protect of the card are connected to GPIOs of the TQMa35.

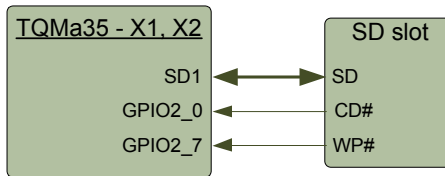

Illustration 13: Block diagram external SD card

4.1.1.12 Power-IN (X6)

For protective and EMC reasons the supply input of the STK-MBa35 is designed very robustly.

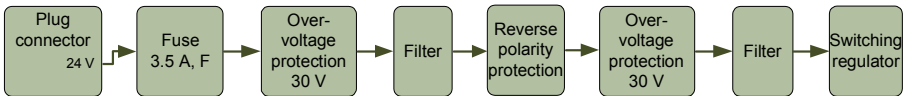

Illustration 14: Block diagram Power-IN

4.1.2 Electrical characteristics

4.1.2.1 Ethernet 1 (X26B)

Type of media:	10/100 Mbit
Interface on module:	MII interface (controller on the module TQMa35)
Status LEDs:	See Table 9 on page 20
Signal characteristic:	Compatible with the IEEE-802.3 standard

4.1.2.2 Ethernet 2 (X26A)

Type of media:	10/100 Mbit
Interface on module:	External memory bus (WEIM) / controller on the STK-MBa35
Status LEDs:	See Table 12 on page 22
Signal characteristic:	Compatible with the IEEE-802.3 standard

4.1.2.3 USB 2.0 Hi-Speed Host (X12-A)

Type of media:	USB 2.0 Hi-Speed, 5 V bus voltage (limited to 500 mA)
Interface on module:	USB Host physical
Signal characteristic:	Compatible with the Universal Serial Bus Specification Rev. 2.0
ESD protection:	±15 kV human body model

4.1.2.4 USB 2.0 Hi-Speed OTG (X12-B)

Type of media:	USB 2.0 OTG Hi-Speed, 5 V bus voltage (limited to 500 mA)
Interface on module:	USB OTG physical (only OTG / cannot be used as device)
Signal characteristic:	Compatible with the Universal Serial Bus Specification Rev. 2.0
ESD protection:	±15 kV human body model

4.1.2.5 RS485 (X32A)

Transfer rate:	Up to 4 Mbit/s (full-duplex)
Interface on module:	UART2
Handshake:	Used for clearing the transmission direction
Signal characteristic:	Compatible with the EIA/TIA-485 standard / galvanically separated
ESD protection:	±15 kV human body model

4.1.2.6 RS232 (X32B)

Transfer rate:	Up to 120 Kbit/s
Interface on module:	UART3 resp. RS232 (optional)
Handshake:	RTS/CTS (via UART3) resp. none (via RS232 from module / optional)
Signal characteristic:	Compatible with the EIA/TIA-232 standard
ESD protection:	±15 kV human body model

4.1.2.7 CAN 1/CAN 2 (X1A)

Transfer rate:	Up to 1 Mbit/s
Interface on module:	CAN1 resp. CAN2
Signal characteristic:	Compatible with the ISO-11898 standard (CAN 2.0B) / galvanically separated
ESD protection:	6 kV human body model

4.1.2.8 GPIO (X1B)

Type of media:	24 V GPIOs (according to the SPS standard)
Interface on module:	I2C1
Signal characteristic:	See Table 4 / <u>not</u> galvanically separated
ESD protection:	600 W pulse power (10 / 1 ms, 0.01 % duty cycle)

Table 4: Electrical characteristics of the GPIOs

Parameter	Min.	Typ.	Max.	Unit
Input frequency (hardware limitation)			15	kHz
Input voltage V_{IN}	0		28	V
Input current ($V_{IN} = 28 V$)			2.5	mA
Positive trigger level (LOW-to-HIGH)	4.4	5.3	7.5	V
Negative trigger level (HIGH-to-LOW)	2.2	3.1	5.3	V

Depending on the operating system and its workload the maximum input frequency can be significantly lower than the value specified by the hardware.

Table 5: Electrical characteristics of the GPOs

Parameter	Min.	Typ.	Max.	Unit
Output frequency			3	kHz
Supply voltage (V_{CC24V_EX})	12	24	30	V
Output voltage (depending on R_{Load})	< V_{CC24V_EX}			V
Load resistance R_{Load}	48			Ω
Load inductance ($V_{CC24V_EX} = 24 V$, $R_{Load} = 48 \Omega$)			2	H
Output current of a single output			700	mA
Output current of all outputs together			5	A
Short circuit current ($V_{CC24V_EX} = 24 V$, $R_{Load} = 10 m\Omega$)	0.7		1.7	A

4.1.2.9 SD card (X4)

Type of media:	SD / SDHC card
Interface on module:	SD 4-bit
Signal characteristic:	Compatible with the SD Host Controller Standard Specification version 2.0 Support for high capacity SD memory cards

4.1.2.10 Audio-output right (X27) and left (X28)

SNR (–60 dB Input):	98 dB
THD+N:	–86 dB
Load:	16 Ω
Power output:	58 mW

4.1.2.11 Microphone input (X13)

Input:	Mono
Gain:	Programmable (0, +20, +30, +40 dB)

4.1.2.12 Power-IN (X6)

Table 6: Electrical characteristics of the power supply

Parameter	Min.	Typ.	Max.	Unit
Input voltage	15	24	30	V
Input current		190		mA
Power consumption		4.56		W
Rated current of the fuse		3.5		A
Voltage drop in the fuse			0.13	V
Melting time of the fuse ($t < 10$ ms)		3.9		A ² s
Melting time of the fuse ($I = 10 * I_N$)		3.3		A ² s

The specified standard power supply for the STK-MBa35 is the following:

- IPCX86MM NT REV. 100 ⇒ 18 V (max. 3.9 A)

With the abovementioned power supply the low voltage directives according to EN 60950 are met. In the case where another power supply is used or if the device is supplied from a 24 V power grid, it is the customer's responsibility to make sure the specified maximum ratings and standards are met.

Table 7: Overview of the function groups of the power supply

Parameter	Min.
Reverse voltage protection	Yes, actively via serial FET (max. 30 V for both polarities allowed)
Excess voltage protection	Yes, voltage limitation to 30 V. With lasting excess voltage the assembly can be damaged!
Short circuit protection	Yes. Passive over current protection by soldered ceramic fuse.
Filter	Integrated filters for the power supply input.

4.1.3 Plug connectors and pin assignments

4.1.3.1 Ethernet 1 (X26B)

Table 8: Plug connector Ethernet 1 (X26B)

Manufacturer	Description
Tyco, 6368011-3	<ul style="list-style-type: none"> • Type: 2 × RJ45 jack • Eight contacts each • LEDs: green and yellow • -40 °C to +80 °C

The following table shows the configuration of the plug connector for Ethernet 1.

Table 9: Pin assignment plug connector Ethernet 1 (X26B)

Pin	Signal	Type	Remark
1	TX+	O	Galvanically separated
2	TX-	O	Galvanically separated
3	RX+	I	Galvanically separated
4	Termplane	-	75 Ω, AC coupled to DGND
5	Termplane	-	Connected to pin 4
6	RX-	I	Galvanically separated
7	Termplane	-	75 Ω, AC coupled to DGND
8	Termplane	-	Connected to pin 7
M	DGND	P	Ground housing
LED1	Link_Activity	-	See Table 10 on page 21
LED2	Speed_Indicator	-	See Table 10 on page 21

Two LEDs are used for diagnosis of the interface. The LEDs are visible from the outside and can be configured via the register MR23 of the Ethernet transceiver.

Table 10: Status LEDs Ethernet 1

Register MR23	Status display	Remark
0000	Link OK	Standard for yellow LED
0001	RX/TX activity	Standard for green LED
0010	TX activity	
0011	RX activity	
0100	Collision	
0101	100 BASE-TX mode	
0110	10 BASE-T mode	
0111	Full-duplex	
1000	LED on: Link OK Blinking: RX/TX activity	

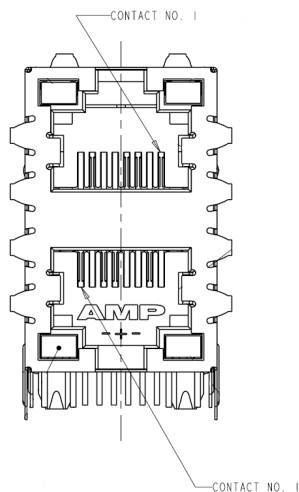

Illustration 15: Wiring of X26B

4.1.3.2 Ethernet 2 (X26A)

Table 11: Plug connector Ethernet 2 (X26A)

Manufacturer	Description
Tyco, 6368011-3	<ul style="list-style-type: none"> Type: 2 × RJ45 jack Eight contacts each LEDs: green and yellow −40 °C to +80 °C

Two LEDs are used for diagnosis of the interface. The LEDs are visible from the outside and have predefined functions.

The following table shows the configuration of the plug connector for Ethernet 2.

Table 12: Pin assignment plug connector Ethernet 2 (X26A)

Pin	Signal	Type	Remark
1	TX+	O	Galvanically separated
2	TX−	O	Galvanically separated
3	RX+	I	Galvanically separated
4	Termination	−	75 Ω, AC coupled to DGND
5	Termination	−	75 Ω, AC coupled to DGND
6	RX−	I	Ethernet 1; galvanically separated
7	Termination	−	75 Ω, AC coupled to DGND
8	Termination	−	75 Ω, AC coupled to DGND
M	DGND	P	Ground housing
LED1	Link_Activity	−	Link activity (green LED) LED on: Valid link and network cable plugged in LED off: No valid link, network cable not plugged in Blinking: Packet transmission (transmission or reception)
LED2	Speed_Indicator	−	Speed indicator (yellow LED) LED on: 100 Mbit/s, disconnected resp. autonegotiation LED off: 10 Mbit/s
LED3 V78	Duplex_Indicator	−	Duplex indicator (green LED) LED on: Full-duplex LED off: Half-duplex LED V78 is visible from outside (positioned on the right hand side of the RJ45 jack)

Wiring of X26A see Illustration 15 on page 21.

4.1.3.3 RS485 (X32A)

Table 13: Plug connector RS485 (X32A)

Manufacturer	Description
Yamaichi, DDP-011S1	<ul style="list-style-type: none"> • Dual standard D-sub connector • 9-pin each • -55 °C to +105 °C

The following table shows the configuration of the plug connector for RS485.

Table 14: Pin assignment plug connector RS485 (X32A)

Pin	Signal	Type	Remark
1	RS485_Y	O	Non inverted output / galvanically separated
2	NC	-	Not connected
3	NC	-	Not connected
4	RS485_A	I	Non inverted input / galvanically separated
5	GND_S2	P	Ground / galvanically separated
6	RS485_Z	O	Inverted output / galvanically separated
7	120R_TX	-	Bridge to pin 1 for 120 Ω termination
8	120R_RX	-	Bridge to pin 9 for 120 Ω termination
9	RS485_B	I	Inverted input / galvanically separated
M	DGND	P	Ground housing

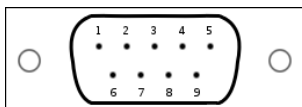

Illustration 16: Wiring of X32A

Attention: Destruction or malfunction!



Due to three physically identical 9-pin D-sub connectors there is the danger of confusion between RS232, RS485 and CAN. The exact arrangement of the interfaces is shown in Illustration 2 on page 9.

4.1.3.4 RS232 (X32B)

Table 15: Plug connector RS232 (X32B)

Manufacturer	Description
Yamaichi, DDP-011S1	<ul style="list-style-type: none"> • Dual Standard D-sub connector • 9-pin each • -55 °C to +105 °C

The following table shows the configuration of the plug connector for RS232.

Table 16: Pin assignment plug connector RS232 (X32B)

Pin	Signal	Type	Remark
1	NC	–	Not connected
2	RS232_RxD	I	Received Data
3	RS232_TxD	O	Transmitted Data
4	NC	–	Not connected
5	DGND	P	Ground
6	NC	–	Not connected
7	RS232_RTS	O	Request To Send
8	RS232_CTS	I	Clear To Send
9	NC	–	Not connected
M	DGND	P	Ground

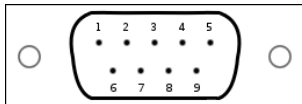

Illustration 17: Wiring of X32B

Attention: Destruction or malfunction!



Due to three physically identical 9-pin D-sub connectors there is the danger of confusion between RS232, RS485 and CAN.
The exact arrangement of the interfaces is shown in Illustration 2 on page 9.

4.1.3.5 CAN 1/CAN 2 (X1A)

Table 17: Plug connector CAN 1 and CAN 2 (X1A)

Manufacturer	Description
Yamaichi, DDPXR-E9P/E15S-C4N-CT	<ul style="list-style-type: none"> • Dual Standard D-sub connector / jack • Top: 9-pin jack • Bottom: 15-pin jack • -55 °C to +105 °C

The following table shows the configuration of the plug connector for both CAN interfaces.

Table 18: Pin assignment plug connector CAN 1 and CAN 2 (X1A)

Pin	Signal	Type	Remark
1	CANL_2	I/O	CAN Low-Level I/O of CAN 2 / galvanically separated
2	CANL_1	I/O	CAN Low-Level I/O of CAN 1 / galvanically separated
3	GND_CAN	P	Ground / galvanically separated
4	CANH_2	I/O	CAN High-Level I/O of CAN 2 / galvanically separated
5	NC	-	Not connected
6	NC	-	Not connected
7	CANH_1	I/O	CAN High-Level I/O of CAN 1 / galvanically separated
8	NC	-	Not connected
9	NC	-	Not connected
M	DGND	P	Ground housing

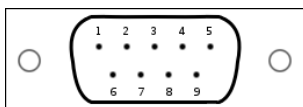

Illustration 18: Wiring of X1A

Attention: Destruction or malfunction!



Due to three physically identical 9-pin D-sub connectors there is the danger of confusion between RS232, RS485 and CAN.
The exact arrangement of the interfaces is shown in Illustration 2 on page 9.

4.1.3.6 GPIO (X1B)

Table 19: Plug connector GPIO (X1B)

Manufacturer	Description
Yamaichi, DDPXR-E9P/E15S-C4N-CT	<ul style="list-style-type: none"> • Dual Standard D-sub connector / jack • Top: connector 9-pin • Bottom: jack 15-pin • -55 °C to +105 °C

The following table shows the configuration of the plug connector for the GPIOs.

Table 20: Pin assignment plug connector GPIO (X1B)

Pin	Signal	Type	Remark
1	IN0	I	Input 0
2	IN1	I	Input 1
3	IN2	I	Input 2
4	IN3	I	Input 3
5	GND_EX	P	Ground
6	VCC24V_EX	P	Supply input for the outputs
7	GND_EX	P	Ground
8	OUT7	O	Output 7
9	OUT6	O	Output 6
10	OUT5	O	Output 5
11	OUT4	O	Output 4
12	OUT3	O	Output 3
13	OUT2	O	Output 2
14	OUT1	O	Output 1
15	OUT0	O	Output 0
M	DGND	P	Ground housing

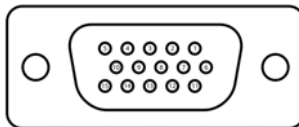

Illustration 19: Wiring of X1B

Attention: Destruction or malfunction!



The 15-pin HD-D-sub connector for GPIO (X1B) looks like a VGA-monitor output. No monitor may be connected there!

4.1.3.7 USB 2.0 Hi-Speed Host (X12-A)

Table 21: Plug connector USB Host (X12-A)

Manufacturer	Description
Yamaichi, USB-A-002A	<ul style="list-style-type: none"> • Dual USB jack, type A • $U_N = 30 \text{ V AC (rms)} / I_N = 1 \text{ A}$ • $U_{\text{max}} = 500 \text{ V AC}$ for 1 minute • $-55 \text{ }^\circ\text{C}$ to $+85 \text{ }^\circ\text{C}$

The following table shows the configuration of the plug connector for the USB Host interface.

Table 22: Pin assignment plug connector USB Host (X12-A)

Pin	Signal	Type	Remark
1	VBUS	P	5 V supply (current limitation to 0.5 A) / 100 μF
2	DM	I/O	Negative differential data line
3	DP	I/O	Positive differential data line
4	DGND	P	Ground
M	DGND	P	Ground housing

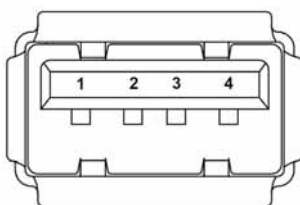

Illustration 20: Wiring of X12-A

4.1.3.8 USB 2.0 Hi-Speed OTG (X12-B)

Table 23: Plug connector USB OTG (X12-B)

Manufacturer	Description
Yamaichi, USB-A-002A	<ul style="list-style-type: none"> • Dual USB jack, type A • $U_N = 30 \text{ V AC (rms)} / I_N = 1 \text{ A}$ • $U_{\max} = 500 \text{ V AC for 1 minute}$ • $-55 \text{ }^\circ\text{C to } +85 \text{ }^\circ\text{C}$

The following table shows the configuration of the plug connector for the USB OTG interface.

Table 24: Pin assignment plug connector USB OTG (X12-B)

Pin	Signal	Type	Remark
1	VBUS	P	5 V supply (current limitation to 0.5 A) / 100 μF
2	DM	I/O	Negative differential data line
3	DP	I/O	Positive differential data line
4	DGND	P	Ground
M	DGND	P	Ground housing

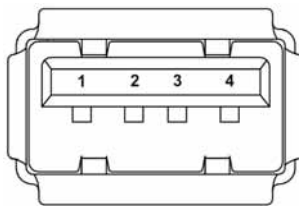

Illustration 21: Wiring of X12-B

4.1.3.9 Audio-output right (X27) and left (X28)

Table 25: Plug connector audio output right (X27) and left (X28)

Manufacturer	Description
Kycon, KLPX-0848A-2-B	<ul style="list-style-type: none"> • RCA phono jack • $U_{\max} = 500 \text{ V AC}$ for 1 minute • $-25 \text{ }^{\circ}\text{C}$ to $+85 \text{ }^{\circ}\text{C}$

The following table shows the configuration of the plug connector for the right audio-output.

Table 26: Pin assignment plug connector audio output right (X27) and left (X28)

Pin	Signal	Type	Remark
1	GND	P	Ground
2	OUTR	AO	Analog audio output right

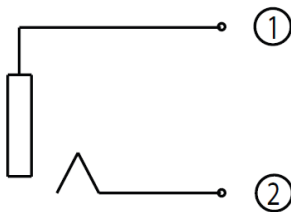

Illustration 22: Wiring of X27 / X28

4.1.3.10 Microphone input (X13)

Table 27: Plug connector microphone (X13)

Manufacturer	Description
Yamaichi, AJ330-4T-SMT	<ul style="list-style-type: none"> • 3.5 mm stereo jack • 5,000 mating cycles • $U_{\max} = 500 \text{ V AC}$ for 1 minute

The following table shows the configuration of the plug connector for the microphone input.

Table 28: Pin assignment plug connector microphone (X13)

Pin	Signal	Type	Remark
1	AGND	P	Ground
2	AGND	P	22 k Ω to ground
3	MIC_IN	AI	Analog microphone input
4	NC	–	Not connected

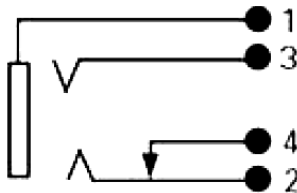

Illustration 23: Wiring of X13

4.1.3.11 SD card (X4)

Table 29: Plug connector external SD card (X4)

Manufacturer	Description
Yamaichi, FPS009-2405-0	<ul style="list-style-type: none"> • SD card and MMC reader • 10,000 mating cycles • $U_{\max} = 500 \text{ V AC}$ for 1 minute

The following table shows the configuration of the plug connector for the external SD card slot.

Table 30: Pin assignment plug connector external SD card (X4)

Pin	Signal	Type	Remark
1	DAT3	I/O	Data line 3, 100 k Ω \uparrow
2	CMD	I/O	Command / response Signal
3	DGND	P	Ground
4	VCC3V3	P	3.3 V supply
5	CLK	I	Clock input 50 MHz
6	DGND	P	Ground
7	DAT0	I/O	Data line 0, 100 k Ω \uparrow
8	DAT1	I/O	Data line 1, 100 k Ω \uparrow
9	DAT2	I/O	Data line 2, 100 k Ω \uparrow
CD	CD	I	Card Detect
WP	WP	I	Write Protect, 10 k Ω \uparrow
COM	DGND	P	Ground

- low active signal, \uparrow - element to VCC5V (pull up), \downarrow - element to ground (pull down), \rightarrow - element in series

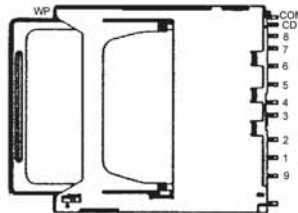

Illustration 24: Wiring of X4

4.1.3.12 Power-IN (X6)

Table 31: Plug connector Power-IN (X6)

Manufacturer	Description
Phoenix Contact, MSTBA 2.5/ 2-G-5.08	<ul style="list-style-type: none"> • Basic package • 5.08 mm pitch • 2-pin • $U_N = 250 \text{ V} / I_N = 12 \text{ A}$

The following table shows the configuration of the plug connector for the 15–30 V power supply.

Table 32: Pin assignment plug connector Power-IN (X6)

Pin	Signal	Type	Remark
1	VCC24V	P	Input supply voltage
2	GND	P	Ground

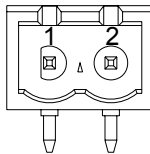

Illustration 25: Wiring of X6
(View on contacts from outside)

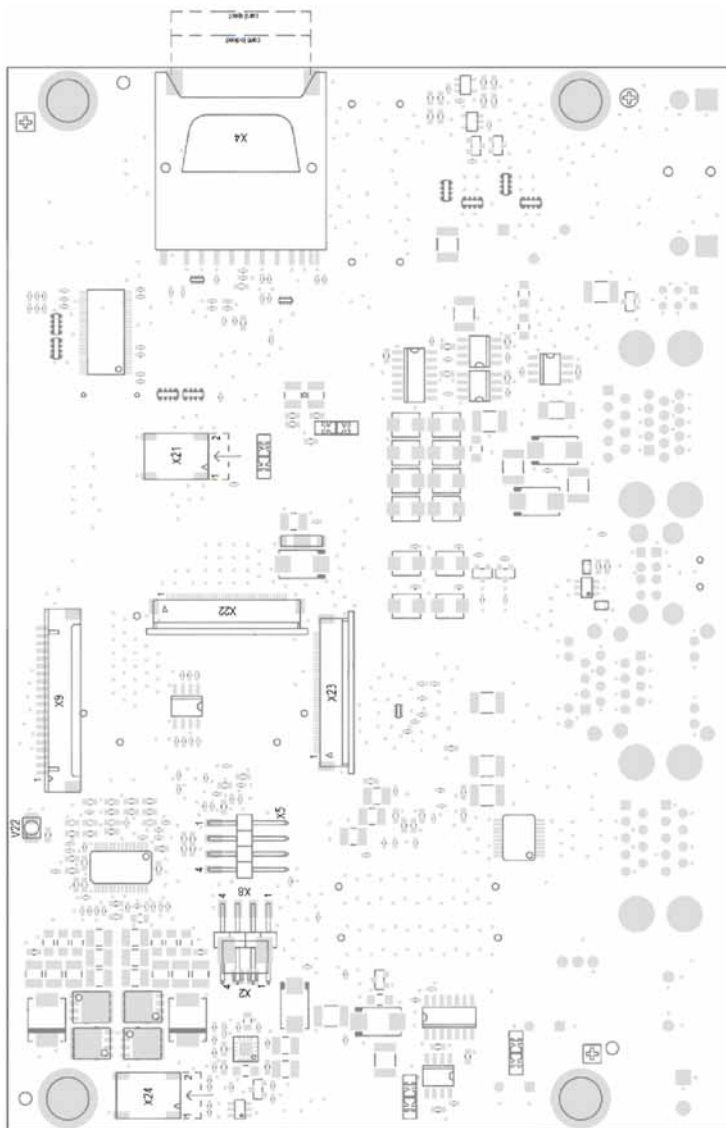

Illustration 27: Component placement bottom

4.2.1 Function specification

4.2.1.1 Module interface (D10)

The module interface of the TQMa35 module on which the module is plugged consists of two or three plug connectors.

Attention: Destruction or malfunction!



To avoid damages caused by mechanical stress, the TQMa35 may only be extracted from the baseboard by using the extraction tool MOZI8XXL. 2.5 mm should be kept free on the baseboard, along the longitudinal edges on both sides of the module for the extraction tool MOZI8XXL.

4.2.1.2 JTAG (X16)

On the TQMa35 the CPU's JTAG interface is routed directly to a 2.54 mm pitch header.

Attention: Destruction or malfunction!



The JTAG signals at the plug connector are directly routed to the CPU. No ESD measures are taken, as it is an internal interface.

4.2.1.3 LCD (X22, X23)

On the STK-MBa35 the LCD bus of the TQMa35 is conditioned by a Texas Instruments driver 74LVC541 and routed to two FFC plug connectors (placement option). For EMC reasons every signal of the LCD bus is terminated with $22\ \Omega$.

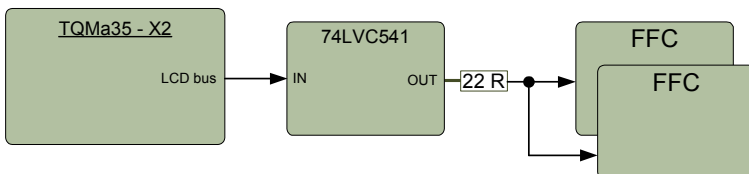

Illustration 28: Block diagram LCD

4.2.1.4 LCD backlight (X21, X24, X5)

As a placement option the STK-MBa35 offers a driver for displays with LED backlight. A Linear Technology LT3518 is used for this purpose. A 12 V supply of up to 2 A, as well as the signals LD_BKL_ON and LD_CONTRAST are available at another plug connector.

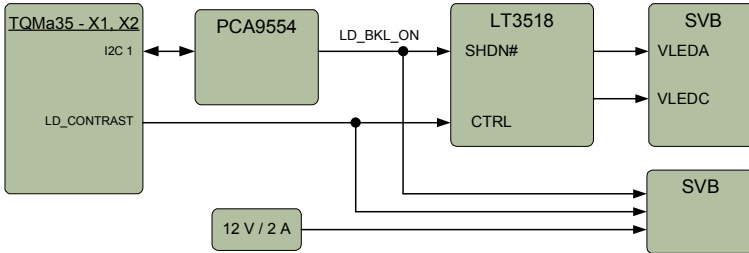

Illustration 29: Block diagram LCD backlight

In Table 3 on page 14 the mapping of the signal LD_BKL_ON is described.

4.2.1.5 Touchscreen (X2, X8)

A Texas Instruments ADS7846N touch controller is integrated on the STK-MBa35, which is routed to the SPI2 interface of the TQMa35. In this way a 4-wire touchscreen can be connected to the STK-MBa35. The lines of the touchscreen are equipped with protective ESD diodes, as well as a CLC filter.

Two plug connectors are available as placement option: an FFC plug connector with 1.25 mm pitch, or a header with 2.54 mm pitch.

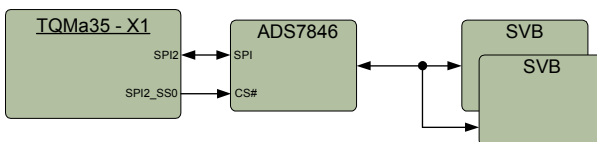

Illustration 30: Block diagram touchscreen

In Table 3 on page 14 the mapping of the signal LCL_LVDS-ENA is described.

4.2.1.6 LVDS Display (X9)

An LVDS transmitter, which transforms the data signals of the LCD bus to LVDS level, is implemented on the STK-MBa35 as a placement option. A Texas Instruments SN75LVDS83B is used for this.

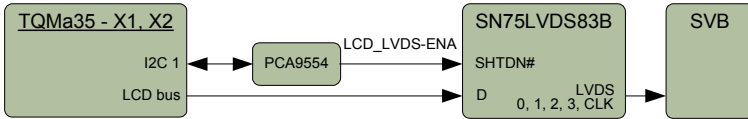

Illustration 31: Block diagram LVDS Display

Table 33: Allocation of RGB signals on LVDS lines

Input SN75LVDS83B	TQMa35 signal	Remark
D0	LD16	
D1	LD17	
D2	LD18	
D3	LD19	
D4	LD20	
D5	LD23	
D6	LD21	
D7	LD8	
D8	LD9	
D9	LD10	
D10	LD14	
D11	LD15	
D12	LD11	
D13	LD12	
D14	LD13	
D15	LD0	
D16	LD6	
D17	LD7	
D18	LD1	
D19	LD2	
D20	LD3	
D21	LD4	
D22	LD5	
D23	-	Pull-down
D24	LD_HSYNC	
D25	LD_VSYNC	
D26	LD_DRDY	
D27	LD22	
CLKIN	LD_CLK	
CLKSEL		Pull-down

In the i.MX35 Reference Manual the assignment of the RGB signals on the LCD bus of the i.MX35 can be looked up.

4.2.1.7 SD card (X25)

The internal SD card is connected to the SD3 bus of the TQMa35. Card-Detect and Write-Protect of the card are routed to GPIOs of the TQMa35.

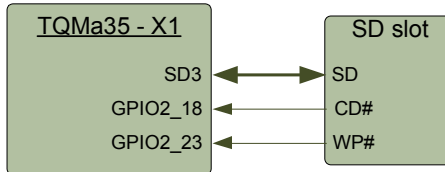

Illustration 32: Block diagram internal SD card

Attention: Usage of SD interface



The internal SD card may only be used if a TQMa35 module without eMMC flash is used.

4.2.1.8 Power-On (X19)

The power-on interface can be used to wake up the TQMa35 from standby and sleep state by a keystroke. The input at the TQMa35 must be configured accordingly.

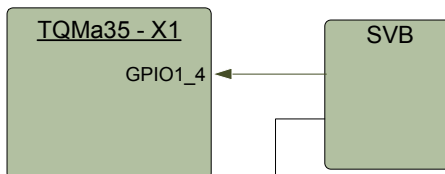

Illustration 33: Block diagram Power-On

4.2.1.9 Starterkit interfaces (X7, X10, X14, X15, X18, X31)

In order to be able to use all applicable processor signals several headers are assembled on the STK-MBa35 when it is used as a Starterkit.

Attention: Destruction or malfunction!



The signals on the Starterkit interfaces are directly routed to the CPU. No ESD measures are taken as these are internal interfaces.

4.2.2 Electrical characteristics

4.2.2.1 LCD (X22, X23)

Type of interface:	RGB, 18 bit
Control signals:	Clock, Data enable
Configuration:	The configuration of the LCD interface can be looked up in the i.MX35 Reference Manual

The following displays are supported by the STK-MBa35:

- PowerView T070W2D2
- Data Image FG0700K5DSSWBG01
- Admatec NLC800T70D480CTMK

4.2.2.2 LCD backlight (X21, X24, X5)

4.2.2.2.1 LED driver (X21, X24)

Output current: 200 mA (app. 10 V)

The LED driver is designed for the supported displays (Admatec, PowerView).

4.2.2.2.2 Backlight power supply (X5)

Type:	Buck regulator
Voltage:	12 V
Current _{max} :	2 A



4.2.2.3 Touchscreen (X2, X8)

Interface on module:	SPI2
Interface touchscreen:	4-wire
ESD protection:	±15 kV AD, ±8 kV CD

4.2.2.4 LVDS Display (X9)

Type of interface:	LVDS 18 bit / 24 bit
Differential pairs:	3 × data, 1 × clock
Control signals:	Clock, HSYNC, VSYNC, and DRDY
Configuration:	The configuration of the LCD interface can be looked up in the i.MX35 Reference Manual
ESD protection:	±5 kV human body model

4.2.2.5 SD card (X25)

Type of media:	SD / SDHC card
Interface on module:	SD 4-bit
Signal characteristic:	Compatible with the SD Host Controller Standard Specification version 2.0 Support for High Capacity SD memory cards

4.2.2.6 Starterkit interfaces (X7, X10, X14, X15, X18, X31)

All signals are 3.3 V compatible (except for the RS232 signals) at the Starterkit interfaces.

4.2.3 Plug connector and pins assignment

4.2.3.1 Module interface (D10)

Table 34: Plug connector module interface (D10)

Manufacturer	Description
Tyco:	<ul style="list-style-type: none"> Header 120-pin, resp. 80-pin Stack height 5 mm $U_{\max} = 100 \text{ V} / I_{\max} = 0.5 \text{ A}$ 100 mating cycles
X1, X2: 5177986-5	
X3: 5177986-3	

The arrangement of the module plug connectors is shown in the following illustration.

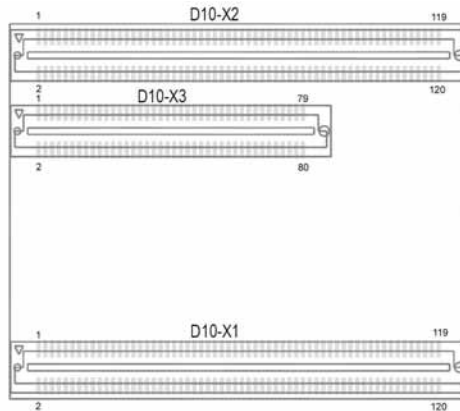

Illustration 34: Wiring of D10

The configuration of the module plug connectors is shown in the following three tables.

Table 35: Pin assignment module plug connector (D10-X1)

Group	Signal	I/O		I/O	Signal	Group		
Power	3V3_VCC	P	1	2	P	VCC3V3	Power	
Power	3V3_VCC	P	3	4	P	VCC3V3	Power	
Power	3V3_VCC	P	5	6	P	VCC3V3	Power	
Power	3V3_VCC	P	7	8	P	VCC3V3	Power	
Power	VBAT	P	9	10	P	DGND	Power	
Power	DGND	P	11	12	P	DGND	Power	
General clock	CLKO	O	13	14	P	DGND	Power	
Power	DGND	P	15	16	P	DGND	Power	
GPIO	GPIO1_4	I/O	17	18	P	DGND	Power	
	GPIO1_5	I/O	19	20	I/O	GPIO1_12	GPIO	
Power	DGND	P	21	22	I/O	GPIO1_22		
GPIO	GPIO2_7	I/O	23	24	I/O	GPIO2_0	4x4 Keypad	
	GPIO2_18	I/O	25	26	P	DGND		Power
	GPIO2_23	I/O	27	28	I/O	COL0		4x4 Keypad
	GPIO2_25	I/O	29	30	I/O	COL1		
Power	DGND	P	31	32	I/O	COL2		
4x4 Keypad	ROW0	I/O	33	34	I/O	COL3	4x4 Keypad	
	ROW1	I/O	35	36	P	DGND		Power
	ROW2	I/O	37	38	I/O	GPIO3_3		GPIO
	ROW3	I/O	39	40	I/O	GPIO3_4		
Power	DGND	P	41	42	I/O	GPIO3_5	SPI 2	
1-Wire	OWDAT	I/O	43	44	I/O	SPI2_S50		
SPI 1	SPI1_S50	I/O	45	46	P	DGND	Power	
	SPI1_S51	I/O	47	48	I/O	SPI2_CLK	SPI 2	
	SPI1_S53	I/O	49	50	I/O	SPI2_MISO		
Power	DGND	P	51	52	I/O	SPI2_MOSI		
SPI 1	SPI1_CLK	I/O	53	54	I	SPI2_RDY	SPI 2	
	SPI1_MISO	I/O	55	56	P	DGND		Power
	SPI1_MOSI	I/O	57	58	I/O	I2C1_SCL		I ² C 1
	SPI1_RDY	I	59	60	I/O	I2C1_SDA		
Power	DGND	P	61	62	I/O	I2C2_SCL	I ² C 2	
Timer	TIM_CAPIN1	I	63	64	I/O	I2C2_SDA		
SD-Card 3	TIM_CMPOUT1	O	65	66	P	DGND	Power	
	SD3_CMD	I/O	67	68	I/O	SD3_DAT0	SD-Card 3	
SD3_CLK	O	69	70	I/O	SD3_DAT1			
Power	DGND	P	71	72	I/O	SD3_DAT2		
SD-Card 3	SD3_DAT4	I/O	73	74	I/O	SD3_DAT3		SD-Card 3
	SD3_DAT5	I/O	75	76	P	DGND	Power	
	SD3_DAT6	I/O	77	78	O	FEC_TXD0	Ethernet Mill	
	SD3_DAT7	I/O	79	80	O	FEC_TXD1		
Power	DGND	P	81	82	O	FEC_TXD2		
Ethernet Mill	FEC_TXD3	O	83	84	I	FEC_TX_CLK		Ethernet Mill
	FEC_TX_ER	O	85	86	P	DGND	Power	
	FEC_TX_EN	O	87	88	I	FEC_RXD0	Ethernet Mill	
	FEC_RXD1	I	89	90	I	FEC_RXD2		
Power	DGND	P	91	92	P	DGND	Power	
Ethernet Mill	FEC_RXD3	I	93	94	I	FEC_RX_CLK	Ethernet Mill	
	FEC_RX_ER	I	95	96	P	DGND	Power	
	FEC_RX_DV	I	97	98	I/O	FEC_MDIO	Ethernet Mill	
	FEC_MDC	O	99	100	I	FEC_CRS		
Power	DGND	P	101	102	I	FEC_COL	CAN 2	
CAN 2	CAN2_TX	I/O	103	104	I	CAN2_RX		
CAN 1	CAN1_TX	I/O	105	106	P	DGND	Power	
	CAN1_RX	I/O	107	108	I	UART3_RTS	UART 3	
UART 3	UART3_CTS	O	109	110	O	UART3_TXD		
Power	DGND	P	111	112	I	UART3_RXD		UART 2
UART 2	UART2_RTS	I	113	114	O	UART2_CTS	UART 2	
	UART2_TXD	O	115	116	P	DGND		Power
	Power	DGND	P	117	118	O	RS232_TXD	RS232
Power	DGND	P	119	120	I	RS232_RXD		

X1

Table 36: Pin assignment module plug connector (D10-X2)

Group	Signal	I/O		I/O	Signal	Group	
Power	DGND	P	1	2	O	FLASH_RESET#	NOR-Flash-CTRL
Reserve	NC	-	3	4	O	WP#_ACC	
	NC	-	5	6	P	DGND	Power
Power Management	VSTBY	I	7	8	I	WDOG_RST#	Reset
Timer	PWM	O	9	10	I	JTAG_RESET#	
Power	DGND	P	11	12	I	RESET_IN#	
SSI 4	SSI_TXD	I/O	13	14	O	POR#	Power
	SSI_RXD	I/O	15	16	P	DGND	
	SSI_TXC	I/O	17	18	O	LD0	
	SSI_TXFS	I/O	19	20	O	LD1	
Power	DGND	P	21	22	O	LD2	IPU-LCD
IPU-LCD	LD3	O	23	24	O	LD4	
	LD5	O	25	26	P	DGND	Power
	LD7	O	27	28	O	LD6	IPU-LCD
	LD9	O	29	30	O	LD8	
Power	DGND	P	31	32	O	LD10	
IPU-LCD	LD11	O	33	34	O	LD12	Power
	LD13	O	35	36	P	DGND	
	LD15	O	37	38	O	LD14	
	LD17	O	39	40	O	LD16	
Power	DGND	P	41	42	O	LD18	IPU-LCD
IPU-LCD	LD19	O	43	44	O	LD20	
	LD21	O	45	46	P	DGND	Power
	LD23	O	47	48	O	LD22	IPU-LCD
	LD_DRDY	O	49	50	O	LD_SPL	
Power	DGND	P	51	52	O	LD_REV	
IPU-LCD	LD_HSYC	O	53	54	O	LD_CLS	Power
	LD_VSYC	O	55	56	P	DGND	
Power	DGND	P	57	58	O	LD_CONTRAST	IPU-LCD
IPU-LCD	LD_CLK	O	59	60	I	USBHS_OC	USB Host Hi-Speed
Power	DGND	P	61	62	O	USBHS_PSW#	
USB Host Hi-Speed	USBHS_UID	I	63	64	I/O	USBHS_VBUS	
Power	DGND	P	65	66	P	DGND	Power
USB Host Hi-Speed	USBHS_UDP	I/O	67	68	I	USBOTG_OC	USB OTG Hi-Speed
	USBHS_UDM	I/O	69	70	O	USBOTG_PSW#	
Power	DGND	P	71	72	I	USBOTG_UID	
USB OTG Hi-Speed	USBOTG_UDM	I/O	73	74	I/O	USBOTG_VBUS	
	USBOTG_UDP	I/O	75	76	P	DGND	Power
Power	DGND	P	77	78	I/O	SD1_DAT0	SD-Card 1
SD-Card 1	SD1_CLK	O	79	80	I/O	SD1_DAT1	
Power	DGND	P	81	82	I/O	SD1_DAT2	
SD-Card 1	SD1_CMD	I/O	83	84	I/O	SD1_DAT3	
IPU-CSI	CSI_D1	I	85	86	P	DGND	Power
	CSI_D3	I	87	88	I	CSI_D0	IPU-CSI
	CSI_D5	I	89	90	I	CSI_D2	
Power	DGND	P	91	92	I	CSI_D4	
IPU-CSI	CSI_D7	I	93	94	I	CSI_D6	Power
	CSI_D9	I	95	96	P	DGND	
	CSI_D11	I	97	98	I	CSI_D8	
	CSI_D13	I	99	100	I	CSI_D10	
Power	DGND	P	101	102	I	CSI_D12	IPU-CSI
IPU-CSI	CSI_D15	I	103	104	I	CSI_D14	
	CSI_VSYNC	I	105	106	P	DGND	Power
	CSI_HSYNC	I	107	108	O	CSI_MCLK	IPU-CSI
	CSI_PIXCLK	I	109	110	I/O	DE#	CPU-JTAG
Power	DGND	P	111	112	O	RTCK	
CPU-JTAG	TCK	I	113	114	I	JTAG_MOD	
	TMS	I	115	116	P	DGND	Power
	TDI	I	117	118	O	TDO	CPU-JTAG
Power	DGND	P	119	120	I	TRST#	

X2

Table 37: Pin assignment module plug connector (D10-X3)

Group	Signal	I/O			I/O	Signal	Group
Power	DGND	P	1	X3	2	I/O D0	16 Bit data bus
16 Bit data bus	D1	I/O	3		4	I/O D2	
	D3	I/O	5		6	P DGND	Power
	D5	I/O	7		8	I/O D4	16 Bit data bus
	D7	I/O	9		10	I/O D6	
Power	DGND	P	11		12	I/O D8	
16 Bit data bus	D9	I/O	13		14	I/O D10	
	D11	I/O	15		16	P DGND	Power
	D13	I/O	17		18	I/O D12	16 Bit data bus
	D15	I/O	19		20	I/O D14	
Power	DGND	P	21		22	O A0	26 Bit address bus
26 Bit address bus	A1	O	23		24	O A2	
	A3	O	25		26	P DGND	Power
	A5	O	27		28	O A4	26 Bit address bus
	A7	O	29		30	O A6	
Power	DGND	P	31		32	O A8	
26 Bit address bus	A9	O	33		34	O A10	
	A11	O	35		36	P DGND	Power
	A13	O	37		38	O A12	26 Bit address bus
	A15	O	39		40	O A14	
Power	DGND	P	41		42	O A16	
26 Bit address bus	A17	O	43		44	O A18	
	A19	O	45		46	P DGND	Power
	A21	O	47		48	O A20	26 Bit address bus
	A23	O	49		50	O A22	
Power	DGND	P	51		52	O A24	
26 Bit address bus	A25	O	53		54	O LBA#	
Bus-CTRL	DTACK#	I	55		56	P DGND	Power
Power	DGND	P	57		58	O RW#	Bus-CTRL
Bus-CTRL	BUS_CLK	O	59		60	O OE#	
Power	DGND	P	61		62	I ECB#	
Bus-CTRL	EB1#	O	63		64	O EBO#	
	CS1#	O	65	66	P DGND	Power	
	CS5#	O	67	68	- DNC	Factory Test only	
Factory Test only	DNC	-	69	- DNC			
Power	DGND	P	71	72	- DNC		
Factory Test only	DNC	-	73	74	- DNC		
	DNC	-	75	76	P DGND	Power	
	DNC	-	77	78	- NC	Reserve	
Power	DGND	P	79	80	- NC		

4.2.3.2 JTAG (X16)

Table 38: Plug connector JTAG (X16)

Manufacturer	Description
Samtec, TSM-107-01-L-DV	<ul style="list-style-type: none"> Header 2.54 mm, 7 × 2-pin

The following table shows the configuration of the JTAG plug connector.

Table 39: Pin assignment plug connector JTAG (X16)

Pin	Signal	Type	Remark
1	VCC3V3	P	Supply voltage 3.3 V
2	DGND	P	Ground
3	JTAG_TRST#	I	Test Reset
4	DGND	P	Ground
5	JTAG_TDI	I	Test Data In
6	NC	–	
7	JTAG_TMS	I	Test Mode Select
8	MR_RESET#	I	0 Ω, not assembled
9	JTAG_TCK	I	Test Clock
10	JTAG_MOD	I	0 Ω, not assembled
11	JTAG_TDO	O	Test Data Out
12	JTAG_RST#	I	Global module reset
13	JTAG_DE#	I/O	Debug Request, 0 Ω, not assembled
14	JTAG_RTCK	O	Return Clock, 0 Ω, not assembled

- low active signal, ↑ - element to VCC5V (pull up), ↓ - element to ground (pull down), → - element in series

Polarity see Illustration 26 on page 33.

4.2.3.3 LCD (X22, X23)

Table 40: Plug connector LCD (X22, X23)

Manufacturer	Description
Yamaichi, FPC-98210-4021	<ul style="list-style-type: none"> FPC plug connector 0.5 mm pitch $U_N = 50 \text{ V} / I_N = 0.5 \text{ A}$ Minimum 30 mating cycles $-20 \text{ }^\circ\text{C}$ to $+85 \text{ }^\circ\text{C}$

Table 41: Pin assignment plug connector LCD (X22, X23)

PowerView Data Image (X22)	Admatec (X23)	Signal	Type	Remark
1	–	GND	P	Ground
2	–	GND	P	Ground
3	–	PowerView: NC Data Image: ADJ	– O	PowerView: 100 kΩ Data Image: LCD_CONTRAST (PWM)
4	40	PowerView/Admatec: VCC3V3 Data Image: VCC5V	P p	Supply voltage
5	39	PowerView/Admatec: VCC3V3 Data Image: VCC5V	P p	Supply voltage
6	38	PowerView/Admatec: VCC3V3 Data Image: VCC5V	P p	Supply voltage
7	37	VCC3V3	P	Supply voltage
8	–	PowerView: NC Data Image: VCC3V3	– P	PowerView: not connected Data Image: Supply voltage
9	35	DATA Enable	O	LCD_OE, 22 Ω →
10	34	GND	P	Ground
11	32	GND	P	Ground
12	30	GND	P	Ground
13	29	Blue 5	O	LCD_D5, 22 Ω →
14	28	Blue 4	O	LCD_D4, 22 Ω →
15	27	Blue 3	O	LCD_D3, 22 Ω →
16	26	GND	P	Ground
17	25	Blue 2	O	LCD_D2, 22 Ω →

PowerView Data Image (X22)	Admatec (X23)	Signal	Type	Remark
18	24	Blue 1	O	LCD_D1, 22 Ω →
19	23	Blue 0	O	LCD_D0, 22 Ω →
20	22	GND	P	Ground
21	21	Green 5	O	LCD_D11, 22 Ω →
22	20	Green 4	O	LCD_D10, 22 Ω →
23	19	Green 3	O	LCD_D9, 22 Ω →
24	18	GND	P	Ground
25	17	Green 2	O	LCD_D8, 22 Ω →
26	16	Green 1	O	LCD_D7, 22 Ω →
27	15	Green 0	O	LCD_D6, 22 Ω →
28	14	GND	P	Ground
29	13	Red 5	O	LCD_D17, 22 Ω →
30	12	Red 4	O	LCD_D16, 22 Ω →
31	11	Red 3	O	LCD_D15, 22 Ω →
32	10	GND	P	Ground
33	9	Red 2	O	LCD_D14, 22 Ω →
34	8	Red 1	O	LCD_D13, 22 Ω →
35	7	Red 0	O	LCD_D12, 22 Ω →
36	5	GND	P	Ground
37	4	GND	P	Ground
38	3	DCLK	O	LCD_SCLK, 22 Ω → / 10 pF ↓
39	2	GND	P	Ground
40	1	GND	P	Ground
-	6	NC	-	not connected
-	31	NC	-	not connected
-	33	NC	-	not connected
-	36	NC	-	not connected

- low active signal, ↑ - element to VCC5V (pull up), ↓ - element to ground (pull down), → - element in series

4.2.3.4 LCD backlight (X21, X24, X5)

Table 42: Plug connector LCD backlight (X21, X24)

Manufacturer	Description
JST, SM02B-BHSS-1-TB	<ul style="list-style-type: none"> • Crimp plug connector • $U_N = 1,400 \text{ V} / I_N = 1 \text{ A}$ • -25 °C to $+85 \text{ °C}$

Table 43: Pin assignment plug connector LCD backlight (X21, X24)

Pin	Signal	Type	Remark
1	VLEDA	P	Anode of LED backlight
2	VLEDC	P	Cathode of LED backlight



Illustration 35: Wiring of X21, X24

Table 44: Plug connector LCD backlight (X5)

Manufacturer	Description
Harwin, M20-8900405	<ul style="list-style-type: none"> • Header 2.54 mm, 1×4-pin • $I_N = 3 \text{ A}$ • -40 °C to $+105 \text{ °C}$

Table 45: Pin assignment plug connector LCD backlight (X5)

Pin	Signal	Type	Remark
1	VCC12V	P	Supply voltage 12 V, alternative 5 V
2	LD_BKL_ON	O	GPIO from PCA9554D to switch the backlight
3	LD_CONTRAST	O	PWM contrast
4	DGND	P	Ground

Wiring see Illustration 27 on page 34.

4.2.3.5 Touchscreen (X2, X8)

Table 46: Plug connector touchscreen (X2)

Manufacturer	Description
JST, 04FFS-SP-TF	<ul style="list-style-type: none"> • FFC plug connector • Pitch 1.25 mm • $U_N = 50 \text{ V}$, $I_N = 0.5 \text{ A}$ • $-25 \text{ }^\circ\text{C}$ to $+85 \text{ }^\circ\text{C}$

Table 47: Plug connector touchscreen (X8)

Manufacturer	Description
Harwin, M20-8900405	<ul style="list-style-type: none"> • Header 2.54 mm • 4 × 1-pin • $I_N = 3 \text{ A}$ • $-40 \text{ }^\circ\text{C}$ to $+105 \text{ }^\circ\text{C}$

Table 48: Pin assignment plug connector touchscreen (X2, X8)

Pin	Signal	Type	Remark
1	Y-	I/P	Touchscreen Bottom
2	X+	I/P	Touchscreen Right
3	Y+	I/P	Touchscreen Top
4	X-	I/P	Touchscreen Left

Wiring see Illustration 27 on page 34.

4.2.3.6 LVDS Display (X9)

Table 49: Plug connector LVDS Display (X9)

Manufacturer	Description
Hirose, DF14-20P-1.25H(25)	<ul style="list-style-type: none"> • Crimp plug connector • $U_N = 150 \text{ V}$, $I_N = 1 \text{ A}$ • -35 °C to $+85 \text{ °C}$

Table 50: Pin assignment plug connector LVDS Display (X9)

Pin	Signal	Type	Remark
1	DGND	P	Ground
2	DGND	P	Ground
3	LVDS3+	O	Data pair 3 positive
4	LVDS3-	O	Data pair 3 negative
5	DGND	P	Ground
6	LVDSCLK+	O	Clock pair positive
7	LVDSCLK-	O	Clock pair negative
8	DGND	P	Ground
9	LVDS2+	O	Data pair 2 positive
10	LVDS2-	O	Data pair 2 negative
11	DGND	P	Ground
12	LVDS1+	O	Data pair 1 positive
13	LVDS1-	O	Data pair 1 negative
14	DGND	P	Ground
15	LVDS0+	O	Data pair 0 positive
16	LVDS0-	O	Data pair 0 negative
17	DGND	P	Ground
18	DGND	P	Ground
19	VCC3V3	P	Supply voltage 3.3 V, alternatively 5 V
20	VCC3V3	P	Supply voltage 3.3 V, alternatively 5 V

Wiring see Illustration 27 on page 34.

4.2.3.7 SD card (X25)

Table 51: Plug connector internal SD card (X25)

Manufacturer	Description
Yamaichi, FPS009-2405-0	<ul style="list-style-type: none"> SD card and MMC reader 10,000 mating cycles $U_{\max} = 500 \text{ V AC}$ for 1 minute

The following table shows the configuration of the plug connector for the internal SD card slot.

Table 52: Pin assignment plug connector internal SD card (X25)

Pin	Signal	Type	Remark
1	DAT3	I/O	Data line 3, 100 k Ω \uparrow
2	CMD	I/O	Command/Response signal
3	DGND	P	Ground
4	VCC3V3	P	3.3 V supply
5	CLK	I	Clock input 50 MHz
6	DGND	P	Ground
7	DAT0	I/O	Data line 0, 100 k Ω \uparrow
8	DAT1	I/O	Data line 1, 100 k Ω \uparrow
9	DAT2	I/O	Data line 2, 100 k Ω \uparrow
CD	CD	I	Card Detect
WP	WP	I	Write Protect, 10 k Ω \uparrow
COM	DGND	P	Ground

- low active signal, \uparrow - element to VCC5V (pull up), \downarrow - element to ground (pull down), \rightarrow - element in series

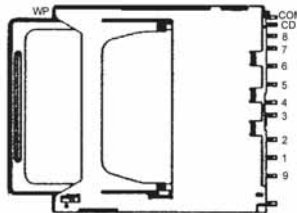

Illustration 36: Wiring of X25

4.2.3.8 Power-On (X19)

Table 53: Plug connector Power-On (X19)

Manufacturer	Description
Samtec, TSM-104-01-LM-SV-P-TR	<ul style="list-style-type: none"> Header 2.54 mm 4 × 1-pin $I_N = 3 \text{ A}$ -55 °C to +125 °C

Table 54: Pin assignment plug connector touchscreen (X2, X8)

Pin	Signal	Type	Remark
1	WAKEUP#	I	TQMa35 GPIO1_4
2	NC	-	RFU
3	NC	-	RFU
4	RFU	P	Ground

- low active signal, ↑ - element to VCC5V (pull up), ↓ - element to ground (pull down), → - element in series

Wiring see Illustration 27 on page 34.

4.2.3.9 Starterkit interfaces (X7, X10, X14, X15, X18, X31)

Almost every signal of the i.MX35 has two or more functions at the Starterkit interfaces. These can be taken from the i.MX35 Reference Manual.

4.2.3.9.1 Starterkit interface (X7)

Table 55: Plug connector Starterkit interface (X7)

Manufacturer	Description
Fischer Elektronik, SL11-SMD-052-10-S	<ul style="list-style-type: none"> • Header 2.54 mm • 5 × 2-pin • -40 °C to +105 °C

Table 56: Plug connector pin assignment Starterkit interface (X7)

Pin	Signal	Type	Remark
1	VCC3V3	P	Supply voltage 3.3 V
2	VCC5V	P	Supply voltage 5 V
3	VCC3V3	P	Supply voltage 3.3 V
4	VCC5V	P	Supply voltage 5 V
5	VCC12V	P	Supply voltage 12 V
6	VCC12V	P	Supply voltage 12 V
7	DGND	P	Ground
8	DGND	P	Ground
9	DGND	P	Ground
10	DGND	P	Ground

Wiring see Illustration 27 on page 34.

4.2.3.9.2 Starterkit interface (X10)

Table 57: Plug connector Starterkit interface (X10)

Manufacturer	Description
Molex, 87759-3075	<ul style="list-style-type: none"> Header 2.00 mm, 15 × 2-pin -55 °C to +105 °C

Table 58: Plug connector pin assignment Starterkit interface (X10)

Pin	Signal	Type	Remark
1	DGND	P	Ground
2	DGND	P	Ground
3	WEIM_A0	O	External memory bus (WEIM bus) address line 0
4	WEIM_A1	O	External memory bus (WEIM bus) address line 1
5	WEIM_A2	O	External memory bus (WEIM bus) address line 2
6	WEIM_A3	O	External memory bus (WEIM bus) address line 3
7	WEIM_A4	O	External memory bus (WEIM bus) address line 4
8	WEIM_A5	O	External memory bus (WEIM bus) address line 5
9	WEIM_A6	O	External memory bus (WEIM bus) address line 6
10	WEIM_A7	O	External memory bus (WEIM bus) address line 7
11	WEIM_A8	O	External memory bus (WEIM bus) address line 8
12	WEIM_A9	O	External memory bus (WEIM bus) address line 9
13	WEIM_A10	O	External memory bus (WEIM bus) address line 10
14	WEIM_A11	O	External memory bus (WEIM bus) address line 11
15	WEIM_A12	O	External memory bus (WEIM bus) address line 12
16	WEIM_A13	O	External memory bus (WEIM bus) address line 13
17	WEIM_A14	O	External memory bus (WEIM bus) address line 14
18	WEIM_A15	O	External memory bus (WEIM bus) address line 15
19	WEIM_A16	O	External memory bus (WEIM bus) address line 16
20	WEIM_A17	O	External memory bus (WEIM bus) address line 17
21	WEIM_A18	O	External memory bus (WEIM bus) address line 18
22	WEIM_A19	O	External memory bus (WEIM bus) address line 19
23	WEIM_A20	O	External memory bus (WEIM bus) address line 20
24	WEIM_A21	O	External memory bus (WEIM bus) address line 21
25	WEIM_A22	O	External memory bus (WEIM bus) address line 22
26	WEIM_A23	O	External memory bus (WEIM bus) address line 23
27	WEIM_A24	O	External memory bus (WEIM bus) address line 24
28	WEIM_A25	O	External memory bus (WEIM bus) address line 25
29	DGND	P	Ground
30	DGND	P	Ground

Wiring see Illustration 27 on page 34.

4.2.3.9.3 Starterkit interface (X14)

Table 59: Plug connector Starterkit interface (X14)

Manufacturer	Description
Molex, 87759-3075	<ul style="list-style-type: none"> Header 2.00 mm, 15 × 2-pin −55 °C to +105 °C

Table 60: Plug connector pin assignment Starterkit interface (X14)

Pin	Signal	Type	Remark
1	DGND	P	Ground
2	DGND	P	Ground
3	WEIM_D0	I/O	External memory bus (WEIM bus) data line 0
4	WEIM_D1	I/O	External memory bus (WEIM bus) data line 1
5	WEIM_D2	I/O	External memory bus (WEIM bus) data line 2
6	WEIM_D3	I/O	External memory bus (WEIM bus) data line 3
7	WEIM_D4	I/O	External memory bus (WEIM bus) data line 4
8	WEIM_D5	I/O	External memory bus (WEIM bus) data line 5
9	WEIM_D6	I/O	External memory bus (WEIM bus) data line 6
10	WEIM_D7	I/O	External memory bus (WEIM bus) data line 7
11	WEIM_D8	I/O	External memory bus (WEIM bus) data line 8
12	WEIM_D9	I/O	External memory bus (WEIM bus) data line 9
13	WEIM_D10	I/O	External memory bus (WEIM bus) data line 10
14	WEIM_D11	I/O	External memory bus (WEIM bus) data line 11
15	WEIM_D12	I/O	External memory bus (WEIM bus) data line 12
16	WEIM_D13	I/O	External memory bus (WEIM bus) data line 13
17	WEIM_D14	I/O	External memory bus (WEIM bus) data line 14
18	WEIM_D15	I/O	External memory bus (WEIM bus) data line 15
19	WEIM_DTACK#	I	External memory bus (WEIM bus) Data transfer acknowledge / wait
20	WEIM_LBA#	O	External memory bus (WEIM bus) Load burst address
21	WEIM_BUSCLK	O	External memory bus (WEIM bus) Burst Clock
22	WEIM_RW#	O	External memory bus (WEIM bus) Read / Write
23	WEIM_ECB#	I	External memory bus (WEIM bus) End current burst / wait
24	WEIM_OE#	O	External memory bus (WEIM bus) Out Enable
25	WEIM_EB0#	O	External memory bus (WEIM bus) Byte Enable 0
26	WEIM_CS1#	O	External memory bus (WEIM bus) Chip Select 1
27	WEIM_EB1#	O	External memory bus (WEIM bus) Byte Enable 1
28	WEIM_CS5#	O	External memory bus (WEIM bus) Chip Select 5
29	DGND	P	Ground
30	DGND	P	Ground

- low active signal, ↑ - element to VCC5V (pull up), ↓ - element to ground (pull down), → - element in series

Wiring see Illustration 27 on page 34.

4.2.3.9.4 Starterkit interface (X15)

Table 61: Plug connector Starterkit interface (X15)

Manufacturer	Description
Molex, 87759-3075	<ul style="list-style-type: none"> Header 2.00 mm, 15 × 2-pin -55 °C to +105 °C

Table 62: Plug connector pin assignment Starterkit interface (X15)

Pin	Signal	Type	Remark
1	DGND	P	Ground
2	DGND	P	Ground
3	CSI_D0	I	Camera Sensor Interface data line 0
4	CSI_D1	I	Camera Sensor Interface data line 1
5	CSI_D2	I	Camera Sensor Interface data line 2
6	CSI_D3	I	Camera Sensor Interface data line 3
7	CSI_D4	I	Camera Sensor Interface data line 4
8	CSI_D5	I	Camera Sensor Interface data line 5
9	CSI_D6	I	Camera Sensor Interface data line 6
10	CSI_D7	I	Camera Sensor Interface data line 7
11	CSI_D8	I	Camera Sensor Interface data line 8
12	CSI_D9	I	Camera Sensor Interface data line 9
13	CSI_D10	I	Camera Sensor Interface data line 10
14	CSI_D11	I	Camera Sensor Interface data line 11
15	CSI_D12	I	Camera Sensor Interface data line 12
16	CSI_D13	I	Camera Sensor Interface data line 13
17	CSI_D14	I	Camera Sensor Interface data line 14
18	CSI_D15	I	Camera Sensor Interface data line 15
19	CSI_HSYNC	I	Camera Sensor Interface HSYNC
20	CSI_VSYNC	I	Camera Sensor Interface VSYNC
21	DGND	P	Ground
22	DGND	P	Ground
23	CSI_MCLK	O	Camera Sensor Interface Master Clock
24	CSI_PIXCLK	I	Camera Sensor Interface Pixel Clock
25	DGND	P	Ground
26	DGND	P	Ground
27	RS232_TX	O	RS232 Transmit (UART1)
28	RS232_RX	I	RS232 Receive (UART1)
29	DGND	P	Ground
30	DGND	P	Ground

Wiring see Illustration 27 on page 34.

4.2.3.9.5 Starterkit interface (X18)

Table 63: Plug connector Starterkit interface (X18)

Manufacturer	Description
Molex, 87759-3075	<ul style="list-style-type: none"> Header 2.00 mm, 15 × 2-pin –55 °C to +105 °C

Table 64: Plug connector pin assignment Starterkit interface (X18)

Pin	Signal	Type	Remark
1	DGND	P	Ground
2	DGND	P	Ground
3	LD_BKL_ON	O	GPIO from PCA9554D to switch the backlight
4	LCD_LVDS-ENA	O	GPIO from PCA9554D to switch on the LVDS transmitter
5	LD_CONTRAST	O	PWM contrast
6	LD_REV	I/O	REV Signal for Sharp displays / GPIO1_3
7	LD_SPL	I/O	SPL Signal for Sharp displays / GPIO1_5
8	LD_CLS	I/O	CLS Signal for Sharp displays / GPIO1_4
9	DGND	P	Ground
10	DGND	P	Ground
11	USER_LED1	O	LED V77 red
12	DGND	P	Ground
13	USER_LED2	O	LED V77 yellow
14	I2C2_SCL	O	I ² C bus 2 clock
15	DGND	P	Ground
16	I2C2_SDA	I/O	I ² C bus 2 data
17	TIMER_CAPIN1	I	Timer Capture
18	DGND	P	Ground
19	DGND	P	Ground
20	I2C1_SCL	O	I ² C bus 1 clock
21	TIMER_CMPOUT1	O	Timer Compare
22	I2C1_SDA	I/O	I ² C bus 1 data
23	DGND	P	Ground
24	DGND	P	Ground
25	CAN1_RxD	I	CAN bus 1 receive
26	CAN2_RxD	I	CAN bus 2 receive
27	CAN1_TxD	O	CAN bus 1 transmit
28	CAN2_TxD	O	CAN bus 2 transmit
29	DGND	P	Ground
30	DGND	P	Ground

Wiring see Illustration 27 on page 34.

4.2.3.9.6 Starterkit interface (X31)

Table 65: Plug connector Starterkit interface (X31)

Manufacturer	Description
Molex, 87759-3075	<ul style="list-style-type: none"> Header 2 00 mm, 15 × 2-pin -55 °C to +105 °C

Table 66: Plug connector pin assignment Starterkit interface (X31)

Pin	Signal	Type	Remark
1	DGND	P	Ground
2	DGND	P	Ground
3	COL0	I/O	4 × 4 KEYPAD
4	ROW0	I/O	
5	COL1	I/O	
6	ROW1	I/O	
7	COL2	I/O	
8	ROW2	I/O	
9	COL3	I/O	
10	ROW3	I/O	
11	DGND	P	Ground
12	DGND	P	Ground
13	DGND	P	Ground
14	OWDAT	I/O	Requires external pull-up resistor
15	SPI1_CLK	O	SPI1 clock
16	DGND	P	Ground
17	SPI1_MISO	I	SPI1 Master In Slave Out
18	VSTBY	O	Standby request to an external PMIC, switches after getting into a standby / low-power mode
19	SPI1_MOSI	O	SPI1 Master Out Slave In
20	DGND	P	Ground
21	SPI1_RDY	O	SPI1 Ready
22	GPIO3_5	I/O	GPIO
23	SPI1_SS0	O	SPI1 Slave Select 0
24	WD0G_RST#	I	Watchdog Reset
25	SPI1_SS1	O	SPI1 Slave Select 1
26	FLASH_RST#	O	Reset signal of the flash memory on the TQMa35
27	SPI1_SS3	O	SPI1 Slave Select 3
28	WP_ACC#	O	WP#/ACC signal of the flash memory on the TQMa35
29	DGND	P	Ground
30	DGND	P	Ground

- low active signal, ↑ - element to VCC5V (pull up), ↓ - element to ground (pull down), → - element in series

Wiring see Illustration 27 on page 34.

4.3 User's interfaces

4.3.1 Reset button (S2)

The reset button resets the CPU, the flash and the USB Host controller on the TQMa35. As a result the CPU generates a reset signal, which resets all other devices (RAM, Ethernet, etc.).

Table 67: Reset button (S2)

Manufacturer	Description
Knitter switch, TMSE 10 J-RA	<ul style="list-style-type: none"> • Miniature pushbutton • Minimum 100,000 operations • Operating force 3 N \pm1 N • Max. 1.27 mm path • -55 °C to +125 °C

4.3.2 Status-LEDs external (V77)

Table 68: External Status-LEDs (V77)

Manufacturer	Description
VS Optoelectronic, WU-2301	<ul style="list-style-type: none"> • 3-fold LED • Red / green / yellow • 0 °C to +80 °C

Three LEDs are implemented in addition to the status LEDs of both Ethernet jacks. Their function can be taken from the following table.

Table 69: Overview external LEDs

LED	Colour	Function / display
V77A	Green	User can define function
V77B	Yellow	User can define function
V77C	Red	Power-On (Voltage regulator indicates power-good)

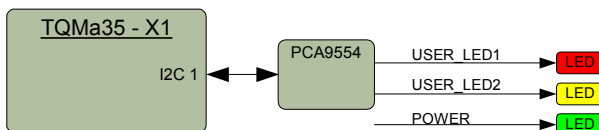

Illustration 37: Block diagram LED

For the control of the LEDs see Table 3 on page 14.

4.3.3 Status-LEDs internal (V22, V24, V25, V46, V78)

Internal LEDs are available to display other functions or status messages. The functions of the LED displays are listed in the following table.

Table 70: Overview internal LEDs

LED	Colour	Function / display
V22	Blue	Power-On (Voltage VCC5V is OK)
V24	Red	Over-current at the USB Host interface
V25	Red	Over-current at the USB OTG interface
V46	Green	Reset to module is active
V78	Green	Ethernet 1 works in full-duplex mode

4.3.4 DIP switch (S1, S3)

The STK-MBa35 possesses two DIP switches whose functions are listed in the following tables.

Table 71: DIP switch S1

Switch	ON	OFF (default)
S3-1	Termination CAN1 (120 Ω)	CAN1 not terminated
S3-2	Termination CAN2 (120 Ω)	CAN2 not terminated
S3-3 ⁽¹⁾	Slew rate configuration for CAN1 disabled	Slew rate configuration for CAN1 enabled
S3-4 ⁽¹⁾	Slew rate configuration for CAN2 disabled	Slew rate configuration for CAN2 enabled

Table 72: DIP switch S3

Switch	ON	OFF (default)
S3-1	No function	No function
S3-2	No function	No function
S3-3	RS485 RxD terminated (120 Ω)	RS485 RxD not terminated
S3-4	RS485 TxD terminated (120 Ω)	RS485 TxD not terminated

¹ To be able to use the switch functions, resistors ≥ 10 kΩ must be equipped for R45 or R50

4.4 System components

4.4.1 Temperature sensor (D22)

Near the LCD plug connectors on the bottom side of the STK-MBa35 is a National Semiconductor LM75 temperature sensor. It can be read out via I²C1. The base address can be taken from the following table.

4.4.2 I²C address allocation

Table 73: I²C address allocation

I ² C bus	Position	Device	Address
1	STK-MBa35	Audio codec – SGT5000	0x0A
1	STK-MBa35	GPO – PCA9554D	0x20
1	STK-MBa35	GPI, USERLED – PCA9554D	0x21
1	STK-MBa35	Temperature sensor – LM75	0x49
2	TQMa35	Temperature sensor – LM75	0x48
2	TQMa35	EEPROM – M24C46*	0x50
2	TQMa35	RTC– DS1339U-33	0x68

*) TQMa35 model dependent

4.4.3 Battery

To supply the RTC of the TQMa35, a lithium battery with very low self-discharge is used. The battery is socketed and, therefore, can be exchanged easily.

Table 74: Component selection battery RTC

Manufacturer	Description
e.g. Sony, CR2032	Lithium battery, typical capacity approx. 200 mAh / 3 V

Attention: Destruction or malfunction!



Reverse polarity of the battery can damage or destroy the device. Attention must be paid to the correct polarity of the battery.

5. SOFTWARE SPECIFICATION

No software is required for the STK-MBa35. Suitable software is only required on the module TQMa35. It is not a part of this specification.

6. MECHANICS SPECIFICATION

6.1 Construction

6.1.1 PCB outlines STK-MBa35

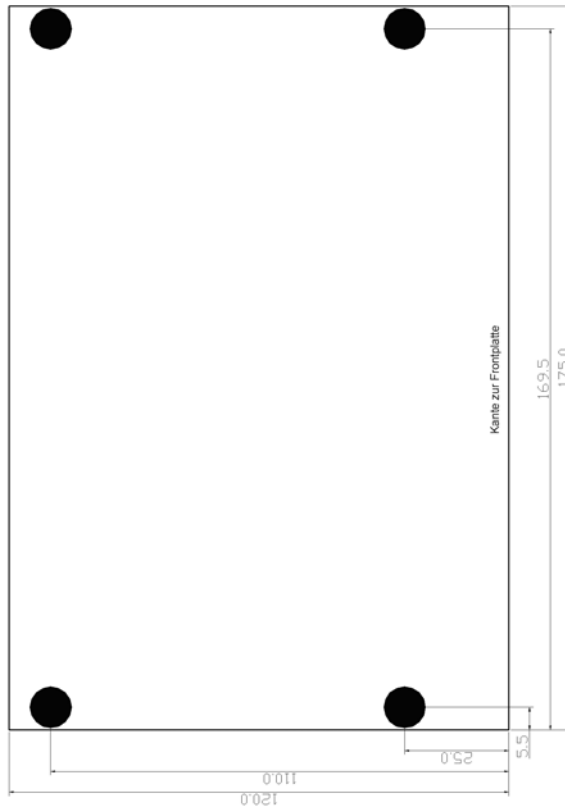

Illustration 38: PCB outlines STK-MBa35

6.1.2 STK-MBa35 top view

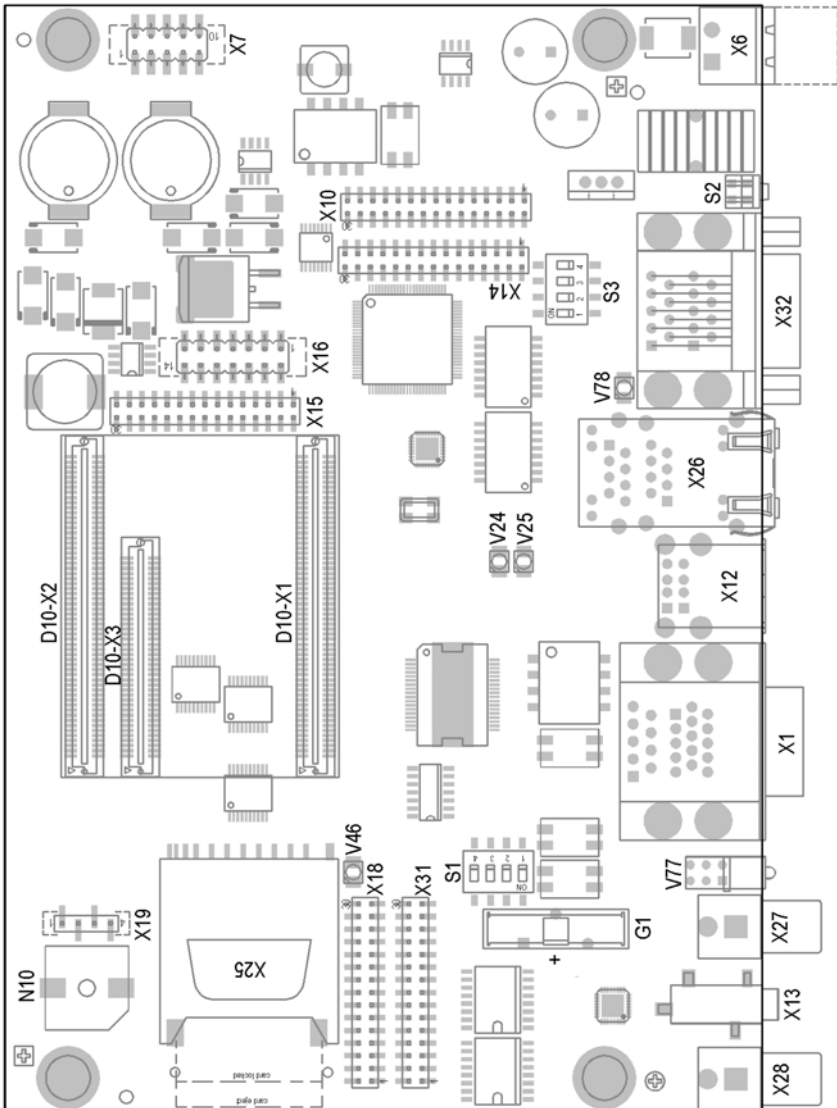

Illustration 39: Top view

6.1.3 STK-MBa35 bottom view

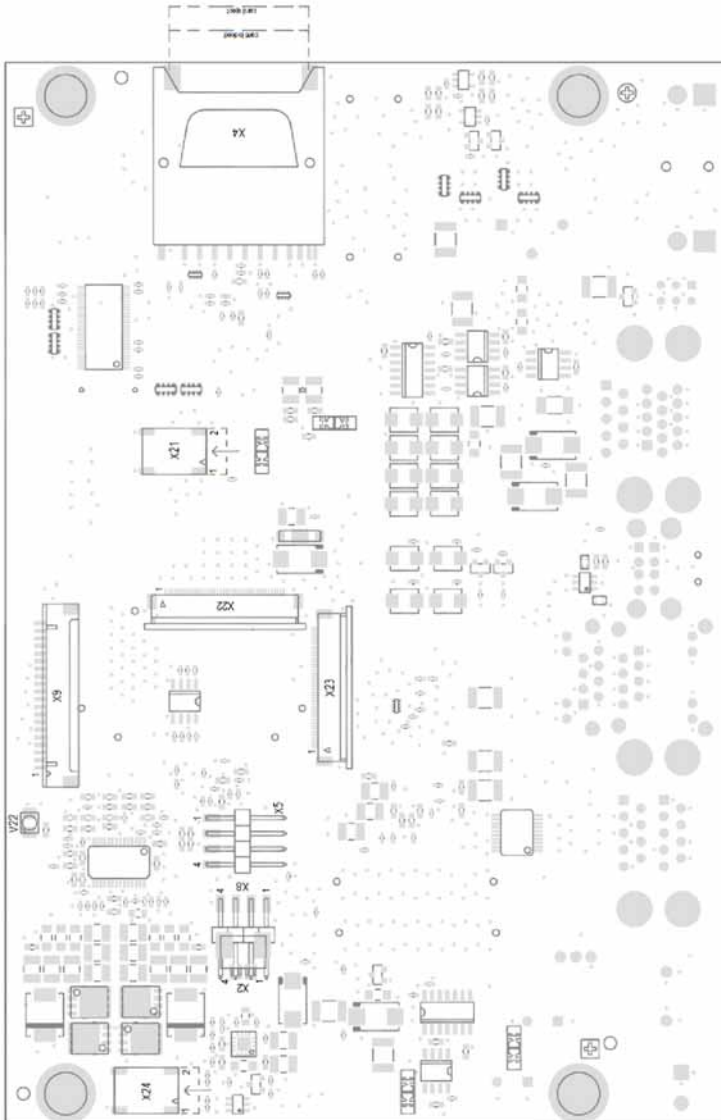

Illustration 40: Bottom view

7. REQUIREMENTS FOR THE SUPERIOR SYSTEM

7.1 Protection against external effects

The STK-MBa35 is not protected against dust, external impact and contact (IP00). An adequate protection has to be guaranteed by the surrounding system.

7.2 Thermal management

The main heat source is the TQMa35. Information to the cooling of the TQMa35 is to be taken from his specification.

8. SAFETY REQUIREMENTS AND PROTECTIVE REGULATIONS

8.1 EMC characteristics

The assembly TQMa35/STK-MBa35 is EMC tested in a TQ Blue-IPC. Current technical concepts were taken into consideration during the development to avoid or reduce EMC interference.

The STK-MBa35 meets the following EMC rules and EMC standards:

- EMC-Interference radiation:
Measurement of the electrically radiated emission for standard, residential, commercial and light industrial environments in the range of 30 MHz to 1 GHz according to DIN EN 61000-6-3 respective DIN EN 55022.
- EMC-Interference radiation:
Measurement of the electrically radiated emission for industrial environments in the range of 30 MHz to 1 GHz according to DIN EN 61000-6-4 respective DIN EN 55011.
- EMC-Immunity according to EN 61000-4-2²⁾:
Electrostatic discharge immunity (ESD).
- EMC-Immunity according to EN 61000-4-3²⁾:
Radiated radio frequency, electromagnetic field immunity.
- EMC-Immunity to fast transients according to EN 61000-4-4²⁾:
Electrical fast transient (BURST).
- EMC-Immunity to surge according to EN 61000-4-5²⁾:
Surge immunity test (SURGE).
In DC networks an inlet length of less than 10 m is assumed.
For the audit a reference power supply has to be defined / supplied.
Signal and I/O lines > 30 m must be checked for SURGE.
- EMC-Immunity according to EN 61000-4-6²⁾:
Immunity to conducted disturbances, induced by radio-frequency fields.
- EMC-Immunity according to EN 61000-4-11²⁾:
Immunity to voltage dips, voltage variation and short interruptions in the mains supply (VOLTAGE DIPS).
- EMC-Immunity according to EN 61000-4-29³⁾:
Immunity to voltage dips and short interruptions on the DC input power supply.

8.2 Operational safety and personal security

Due to the occurring voltages (≤ 36 V DC), tests with respect to the operational and personal safety have not been carried out.

²⁾ The test level and test criteria are taken from the generic standards EN 61000-6-1 and EN 61000-6-2.

³⁾ The test criteria are not fixed here yet, because there are still no generic standards or product standards on which to base this standard. When required the test criteria have to be defined with the customer.

9. CLIMATIC AND OPERATIONAL CONDITIONS

Permitted component temperature:	0 °C to +70 °C
Permitted storage temperature:	-40 °C to +100 °C
Relative air humidity (operation / storing):	10 % to 90 % (not condensing)
Protection class:	IP00

9.1 Protection against external effects

See section 7.1 Protection against external effects on page 65.

9.2 Reliability and product life

The device is designed for a typical product life of five years.

Plug connectors of middle grade, which guarantee at least 100 mating cycles, are used for all external accessible interfaces.

9.3 The used displays

The display manufacturers permit a number of pixel defects. These vary depending on the manufacturer and type of display. The permissible error of the pixel display manufacturers (warranty claims) is usually set very high. TQ-Components GmbH allows pixel errors in the display.

9.4 Batteries

9.4.1 General notes

Due to technical reasons a battery is necessary for this product. Batteries containing mercury (Hg), cadmium (Cd) or lead (Pb) are not used. To allow a separate disposal, batteries are generally only mounted in sockets.

9.4.2 Lithium battery

The following requirements are complied with for Lithium batteries. There is therefore no classification as dangerous goods:

- Basic lithium content per cell * 1 g (except for lithium ion and lithium polymer cells for which a lithium content of * 1.5 g per cell applies).
- Lithium cells and batteries are examined according to UN Manual (document ST/SG/AC.10-1).
- During transport a short circuit or unloading of the socketed lithium battery is prevented by extricable insulating foils or by other suitable insulating measures.

9.5 Environment protection

By environmentally friendly processes, production equipment and products, we contribute to the protection of our environment.

To be able to reuse the product, it is produced in such a way (a modular construction) that it can be easily repaired and disassembled.

The energy consumption of this subassembly is minimised by suitable measures.

Printed pc-boards are delivered in reusable packaging. Modules and devices are delivered in an outer packaging of paper, cardboard or other recyclable material.

Because now there is still no technical equivalent alternative for printed circuit boards with bromine-containing flame protection (FR-4 material), such printed circuit boards are still used.

No use of PCB containing capacitors and transformers (polychlorinated biphenyls).

These points are an essential part of the following laws:

- The law to encourage the circular flow economy and assurance of the environmentally acceptable removal of waste as at 27.9.94 (source of information: BGBl I 1994, 2705)
- Regulation with respect to the utilization and proof of removal as at 1.9.96 (source of information: BGBl I 1996, 1382, (1997, 2860)
- Regulation with respect to the avoidance and utilization of packaging waste as at 21.8.98 (source of information: BGBl I 1998, 2379)
- Regulation with respect to the European Waste Directory as at 1.12.01 (source of information: BGBl I 2001, 3379)

This information is to be seen as notes.

Tests or certifications were not carried out with respect to that.

9.6 RoHS compliance

The STK-MBa35 is manufactured RoHS compliant. TQ-Components GmbH issues the RoHS conformity declaration.

9.7 WEEE regulation

TQ-Components GmbH, which markets the product, is responsible for the observance of the WEEE regulation.

TQ-Components GmbH

Mühlstraße 2 | Gut Delling | 82229 Seefeld
info@tq-components.com | www.tq-group.com

Technologie in Qualität

