

The reproduction, distribution and utilization of this document as well as the communication of its contents to others without express authorization is prohibited. Offenders will be held liable for the payment of damages. All rights reserved in the event of the grant of a patent, utility model or design.

ILM-E85x13 SERVO KIT PCB Section A-A

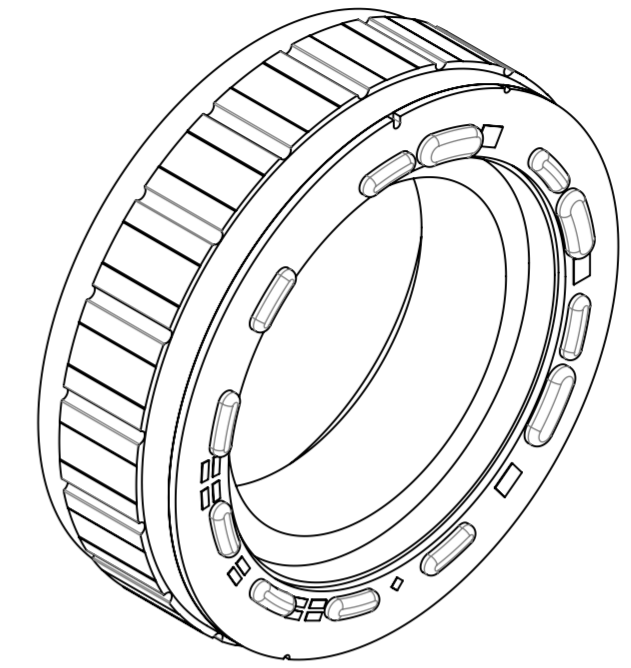

DETAIL F
Scale 2 : 1

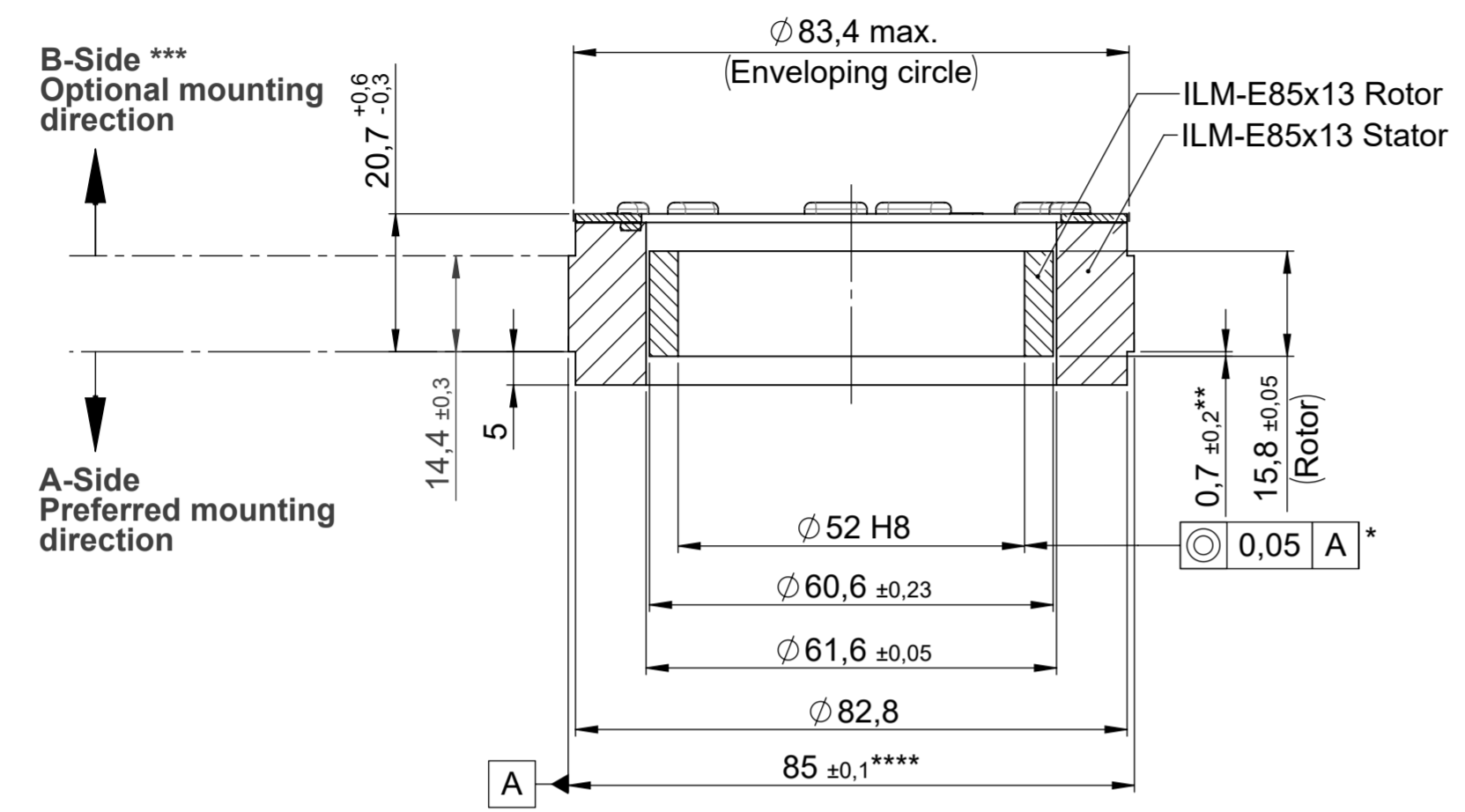
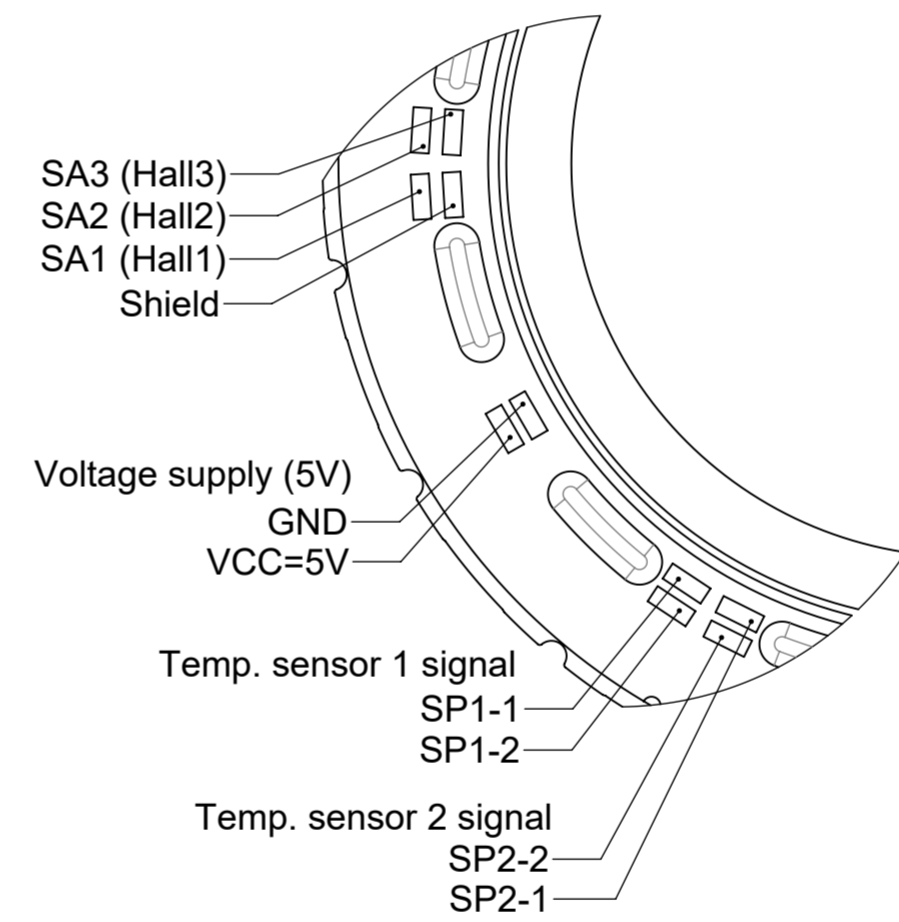

DETAIL E
Scale 2 : 1

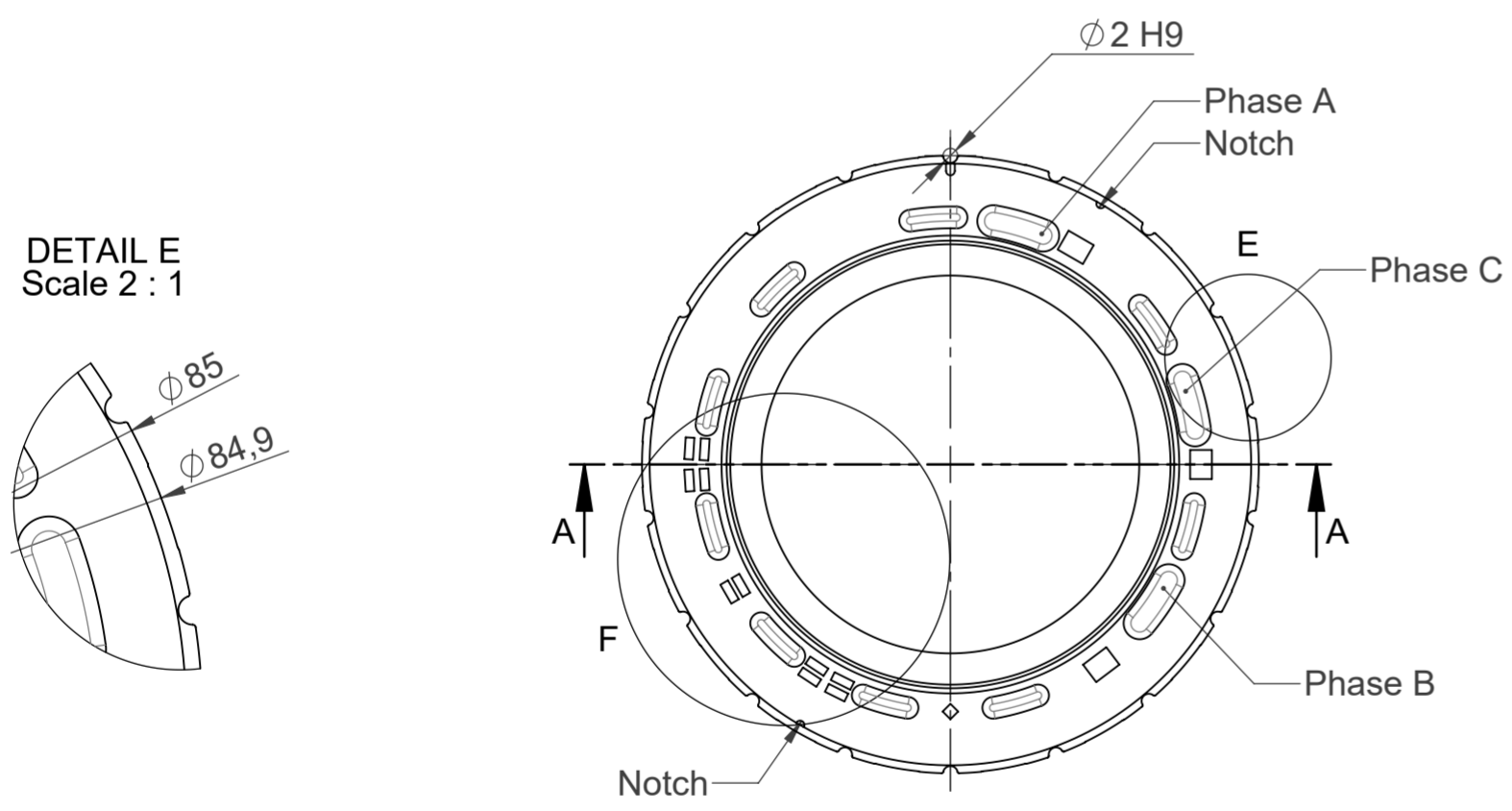

- * In assembly
- ** Rotor position in relation to stator mounting edge
- *** B-Side mounting requires additional TQ design support
- **** Please assume a $\varnothing 85 (+0,085/-0,005)$ fit for the calculation of the press fit

Housing and shaft design according to installation dimensions of motor housing and motor shaft.
Use aluminium housing for integration of the stator.

Compliance to EU-RoHS and EU-REACH, latest edition, must be warranted

ILM-E85x13 SERVO KIT PCB (Interconnection Type)

Identification	Position 1			Position 2		
	Order number	Order name	Amount	Order number	Order name	Amount
ILM-E85x13 SERVO KIT STD VSS	332539.0100	ILM-E85x13 Rotor	1	332805.0100	ILM-E85x13 Stator VSS HALL	1
ILM-E85x13 SERVO KIT STD VSP	332539.0100	ILM-E85x13 Rotor	1	332806.0100	ILM-E85x13 Stator VSP HALL	1
ILM-E85x13 SERVO KIT STD VDS	332539.0100	ILM-E85x13 Rotor	1	332807.0100	ILM-E85x13 Stator VDS HALL	1

Note: Please refer to 3D CAD model for missing dimensions and specifications

ECR Number		ECR Name MeindIA		ECR Description Blatt 2. Gehäusepassung von V7 auf U6 angepasst.		Engineering code E-00137400.01		
		Date	Name	Material				
		Prepared	01.07.2020	MeindIA				
		Checked	21.10.2021	StockM	Part name ILM-E85x13 SERVO KIT PCB INFO			
		Confidentiality level		Number	Rev.	Ind.	Sheet	
Mass 77.25g	Volume 77.84cm³	Scale	1:1	Format	A2	329458.0100 1/2		

The reproduction, distribution and utilization of this document as well as the communication of its contents to others without express authorization is prohibited. Offenders will be held liable for the payment of damages. All rights reserved in the event of the grant of a patent, utility model or design.

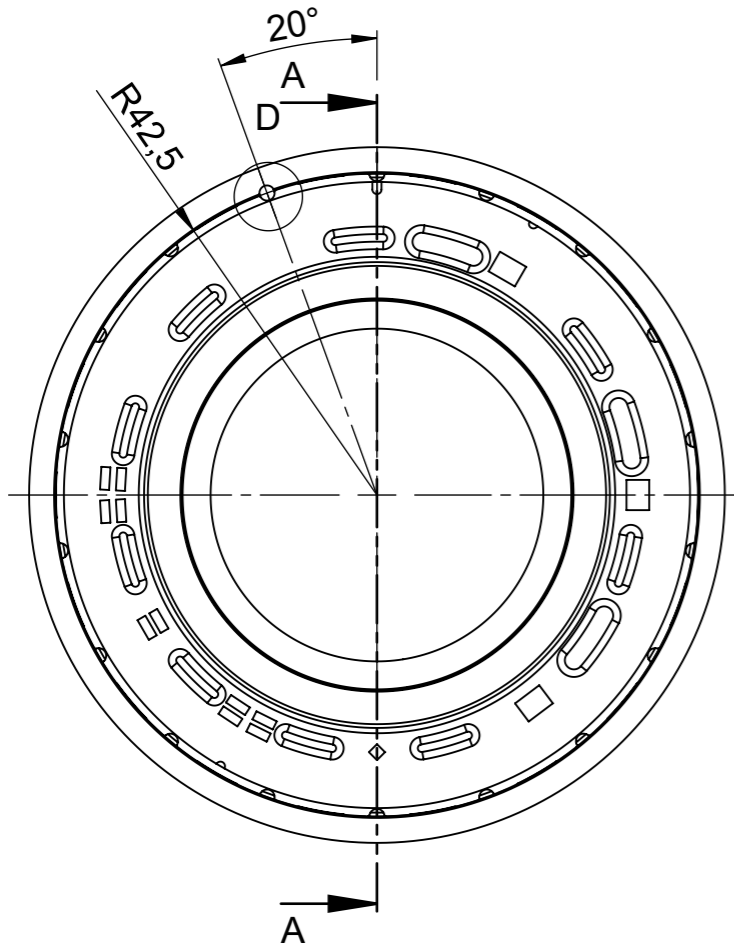

DETAIL D
Scale 5 : 1

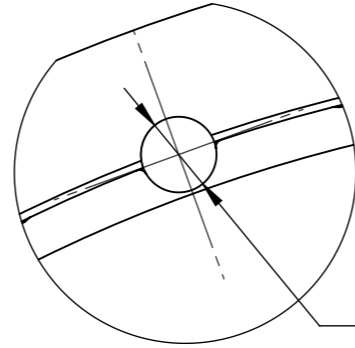

$\phi 2 \text{ H9 } \begin{matrix} (+0,025) \\ 0 \end{matrix}$
 $\phi 0,1$
 Hole for positioning and fixation of the stator

DETAIL C
Scale 3 : 1

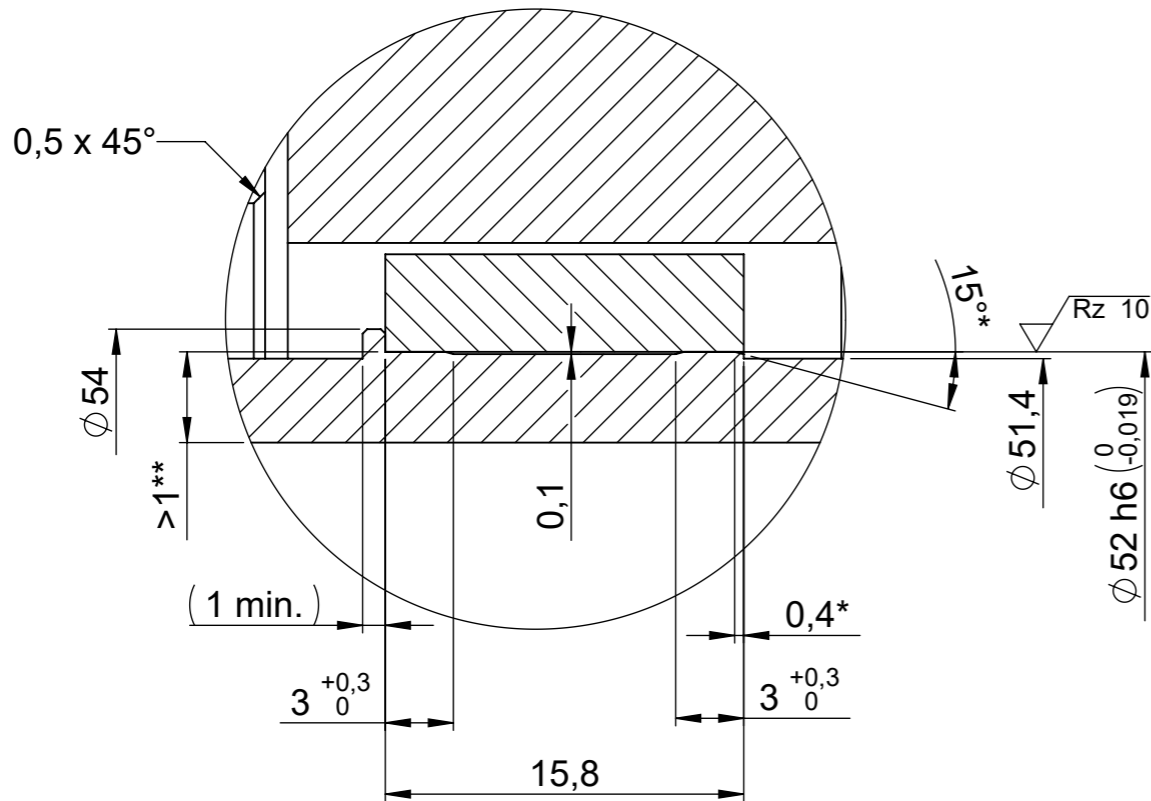

DETAIL B
Section A-A
Scale 2 : 1

A-Side
Preferred mounting
direction

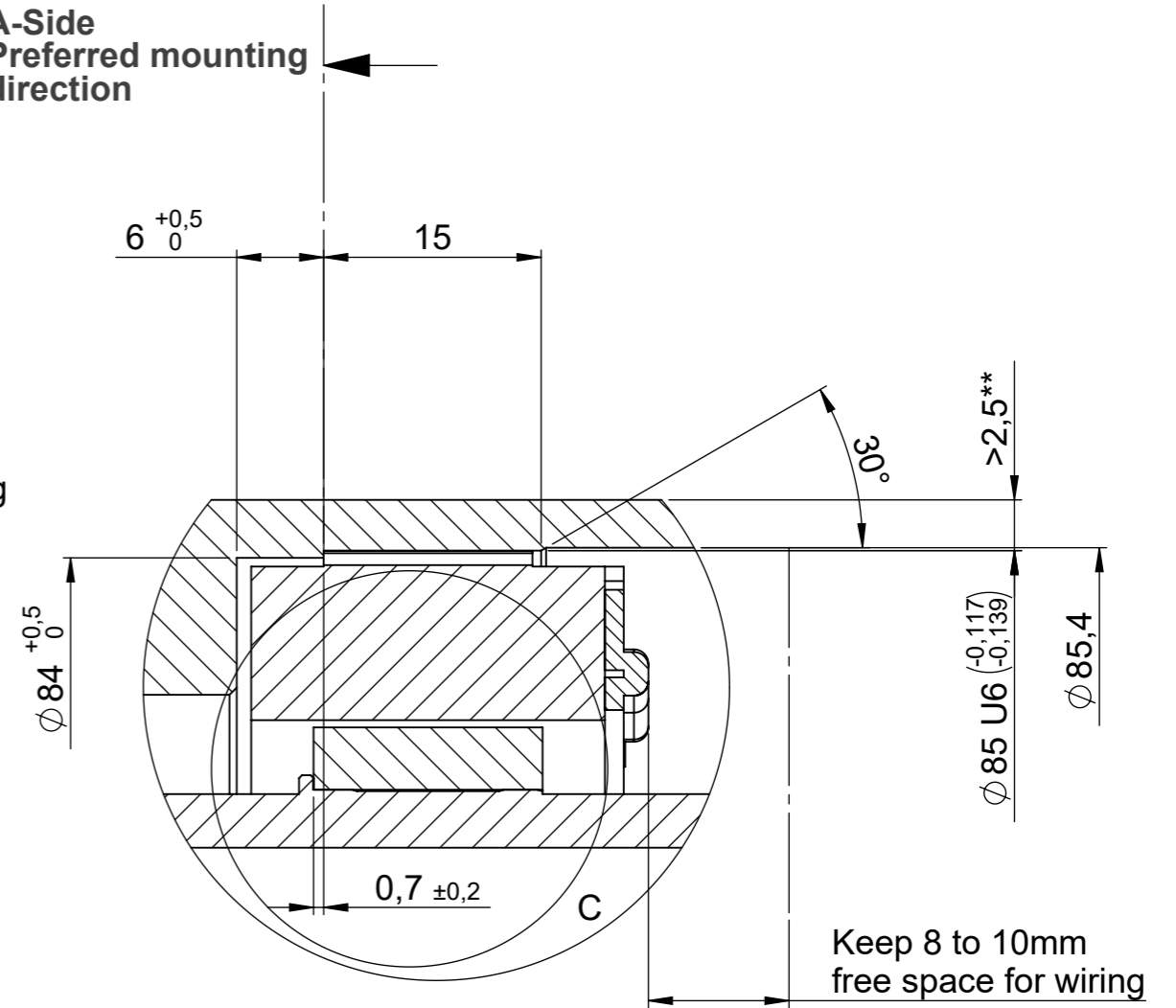



- * Recommended silp bevel
- ** Recommended wall thickness >2,5mm

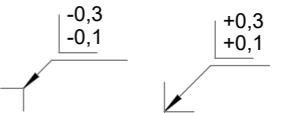

DIN ISO 13715



Compliance to EU-RoHS and EU-REACH, latest edition, must be warranted

ECR Number		ECR Name MeindIA		ECR Description Blatt 2: Gehäusepassung von V7 auf U6 angepasst.		Engineering code E-00137400.01		
		Date	Name	Material				
		Prepared	01.07.2020	MeindIA				
		Checked	21.10.2021	StockM	Part name ILM-E85x13 Einbau Stator PCB - Rotor			
 ISO 8015 DIN ISO 2768 f H		Confidentially level		Number		Rev.	Ind. Sheet	
Mass	Volume	Scale	1:1	Format	A3	329458.0100		
						2/2		