



MBox-R/-V/-VH-E39 User's Guide

MBox-R/V/VH-E39 UG 0100
2021-05-25





TABLE OF CONTENTS

1.	IMPORTANT INFORMATION	1
1.1	General	1
1.2	Symbols and Typographic Conventions	1
1.3	Before You Start	1
1.4	Duty Of Care	1
1.5	Limited Warranty	1
1.6	Liability and Warranty Obligation	1
1.7	Safety Guidelines	2
1.8	Grounding Considerations	2
1.9	ESD Considerations	2
1.10	Handling the MBox-R/-V/-VH-E39	2
1.11	Coin Cell Battery	2
2.	ABOUT THIS MANUAL	3
2.1	Copyright and Licence Expenses	3
2.2	Registered Trademarks	3
2.3	Disclaimer	3
2.4	Imprint	3
2.5	Service, Support, and RMA	3
3.	INTRODUCTION	4
3.1	Functional Overview	4
3.2	MBox-R/-V/-VH-E39 Versions	5
4.	FUNCTIONAL SPECIFICATION	7
4.1	Electrical Specification	7
4.1.1	Supply Voltage Characteristics	7
4.1.2	Power Consumption Specification	7
4.2	Environmental Specification	7
4.3	Connectors and Interfaces	8
4.3.1	External Connectors and Interfaces Arrangement	8
4.3.1.1	Power Supply Connector	10
4.3.1.2	Mini DisplayPort	10
4.3.1.3	USB Host Interfaces	10
4.3.1.4	Gigabit Ethernet	10
4.3.1.5	Status LED	11
4.3.1.6	Power Button and Reset Button	11
4.3.2	Optional External Connectors and Interfaces Arrangement	12
4.3.2.1	Serial Interfaces RS-232	12
4.3.2.2	SMA Antenna Connectors	12
4.3.2.3	Other Optional Connectors	12
4.3.2.4	mSATA Interface for Mass Storage	12
4.3.2.5	Mini PCIe Extension Sockets	12
4.3.2.6	MicroSD Card Socket	12
5.	MECHANICS	13
5.1	Dimensions	13
5.2	Mounting	15
6.	REGULATORY INFORMATION	16
6.1	EU Compliance with Electromagnetic Compatibility Directive EC-Declaration of Conformity	16
7.	WEEE AND RECYCLING	16
7.1	WEEE	16
7.2	Recycling	16
8.	APPENDIX	16
8.1	Driver Download	16



TABLE DIRECTORY

Table 1:	Terms and Conventions	1
Table 2:	MBox-R/-V/-VH-E39 Chassis Options.....	5
Table 3:	MBox-R/-V/-VH-E39 Standard Versions	5
Table 4:	TQMxE39M Module Versions.....	5
Table 5:	Pinout Power-In Connector.....	10
Table 6:	Ethernet LEDs	10
Table 7:	Status LED Conditions.....	11
Table 8:	Power Button and Reset Button Functions	11
Table 9:	RS-232 D-Sub-9 Connector.....	12

FIGURE DIRECTORY

Figure 1:	MBox-R-E39, Front with D-Sub-9 Connectors	8
Figure 2:	MBox-V-E39, Front without D-Sub-9 Connectors / MBox-VH-E39	8
Figure 3:	MBox-R-E39, Rear	9
Figure 4:	MBox-V-E39, Rear (also valid for MBox-VH-E39)	9
Figure 5:	DC Power Supply Connector	10
Figure 6:	Mini DP Connector.....	10
Figure 7:	RJ45 Connectors.....	10
Figure 8:	D-Sub-9 Adapter Cable.....	12
Figure 9:	RS-232 D-Sub-9 Connector.....	12
Figure 10:	MBox-R-E39, Dimensions (mm), Front View	13
Figure 11:	MBox-R-E39, Dimensions (mm), Side View.....	13
Figure 12:	MBox-V-E39 (without D-Sub-9 Connectors), Dimensions (mm), Bottom View.....	14
Figure 13:	MBox-VH-E39 (with D-Sub-9 Connectors), Dimensions (mm), Bottom View	14
Figure 14:	MBox-R-E39, Mounting Dimensions (mm), Top View	15
Figure 15:	MBox-V-E39 / MBox-VH-E39, Dimensions of Mounting Holes (mm), Bottom View.....	15

REVISION HISTORY

Rev.	Date	Name	Pos.	Modification
0100	2021-05-25	FP		First edition, based on MBox-R/V (Update for new embedded module family TQMxE39M)





1. IMPORTANT INFORMATION

1.1 General

Be sure to follow the tips given in this User's Guide to make best use of the MBox-R/-V/-VH-E39. Failure to do so might lead to discomfort or injury, or cause the MBox-R/-V/-VH-E39 to fail.

1.2 Symbols and Typographic Conventions

Table 1: Terms and Conventions

Symbol	Meaning
	This symbol represents the handling of electrostatic-sensitive modules and / or components. These components are often damaged / destroyed by the transmission of a voltage higher than about 50 V. A human body usually only experiences electrostatic discharges above approximately 3,000 V.
	This symbol indicates the possible use of voltages higher than 24 V. Please note the relevant statutory regulations in this regard. Non-compliance with these regulations can lead to serious damage to your health and also cause damage / destruction of the component.
	This symbol indicates a possible source of danger. Acting against the procedure described can lead to possible damage to your health and / or cause damage / destruction of the material used.
	This symbol represents important details or aspects for working with TQ-products.

1.3 Before You Start

This User's Guide must be carefully read and completely understood before you start working with the MBox-R/-V/-VH-E39. This User's Guide provides information, which is essential for proper operation of the MBox-R/-V/-VH-E39. General safety instructions must be adhered to and only trained and authorized personnel is permitted to work with the MBox-R/-V/-VH-E39.

1.4 Duty Of Care

It must be ensured that the MBox-R/-V/-VH-E39 is only used in environments, which meet the specification of the MBox-R/-V/-VH-E39. The User's Guide has to be completely read and understood and the personnel is authorized and trained regarding standards, regulations and instructions. It also has to be ensured, that the MBox-R/-V/-VH-E39 is mounted, operated and maintained according to the instruction of this User's Guide. All applicable national and international regulations and standards have to be obeyed.

1.5 Limited Warranty

Parts which wear out naturally are excluded from the warranty beyond that provided by law. This applies to e.g., coin cell batteries.

1.6 Liability and Warranty Obligation

TQ-Systems GmbH shall be exempted from the statutory accident liability obligation in case the user does not observe the information provided in this User's Guide or the warnings on the device. In the event of damage caused by failure to observe the information provided in this User's Guide or the warnings on the device, TQ-Systems GmbH shall not be required to honour the warranty even during the warranty period and shall be exempted from the statutory accident liability obligation.



1.7 Safety Guidelines

Use the following safety guidelines to protect your MBox-R/-V/-VH-E39 from potential damage and ensure your personal safety. If the following safety guidelines are not observed, it could lead to injuries to the operator and/or damage of the MBox-R/-V/-VH-E39.

In cases of non-observance of the safety guidelines TQ-Systems GmbH is exempt from accident liability, even if the MBox-R/-V/-VH-E39 is still under warranty. The MBox-R/-V/-VH-E39 must be used as specified in this User's Guide, which describes the safety guidelines for the MBox-R/-V/-VH-E39 as well as for the operator. The place where the MBox-R/-V/-VH-E39 is installed has to meet the requirements of the country's standards and regulations. If power cables are delivered with the MBox-R/-V/-VH-E39 only these may be used. Ensure that there is sufficient air circulation to cool the MBox-R/-V/-VH-E39. Do not cover the MBox-R/-V/-VH-E39 or mount it close to heat sources or damp places.

To completely disconnect the MBox-R/-V/-VH-E39 from mains, the power cord has to be disconnected. Make sure the power cord is always easy accessible. Only open the MBox-R/-V/-VH-E39 after all cables are disconnected from the MBox-R/-V/-VH-E39 to insert or remove add-on cards.

This may only be done by qualified personnel. If add-on cards are installed in the MBox-R/-V/-VH-E39, all effective legal regulations and all technical data has to be adhered to. It has to be ensured, that the power consumption of add-on cards does not exceed the limitations and the current consumption specified on the label of the MBox-R/-V/-VH-E39. Very important! A safe operation is not possible when the MBox-R/-V/-VH-E39 is visibly damaged or is not functioning at all. In this case the MBox-R/-V/-VH-E39 must be switched off and it must be ensured that the MBox-R/-V/-VH-E39 cannot be put back into operation. It is very important to ensure that the wires of power cords are sufficiently dimensioned, according to the maximum electrical specifications of the MBox-R/-V/-VH-E39. Standards and regulations like EN62368-1, VDE0100, EN60204, or UL508 have to be adhered to. This information helps you to safely use the MBox-R/-V/-VH-E39.

Follow and keep all information included with the MBox-R/-V/-VH-E39. The information in this User's Guide does not alter the terms of your purchase agreement or the TQ-Systems GmbH Limited Warranty. Your safety is important to us. The MBox-R/-V/-VH-E39 is developed to be safe and effective. Power cords, power adapters, and other features can create potential safety risks that may result in physical injury or property damage, especially if misused. To reduce these risks, follow the instructions in this User's Guide, and observe all warnings on the MBox-R/-V/-VH-E39 and in this User's Guide. By carefully following the information contained in this User's Guide and provided with the MBox-R/-V/-VH-E39, you can help protect yourself from hazards and create a safer environment.

Do not attempt to service the MBox-R/-V/-VH-E39 yourself unless instructed to do so by TQ-Systems GmbH or this User's Guide.

1.8 Grounding Considerations

Be aware, that the chassis of the MBox-R/-V/-VH-E39 is internally connected to Digital Ground (Power Supply Connector GND). Depending on the Power Supply Unit used, it also might be connected or not to protective earth (PE).

This has to be considered, when connecting other components to the MBox-R/-V/-VH-E39.

The grounding of the MBox-R/-V/-VH-E39 might also influence the electromagnetic emission of the MBox-R/-V/-VH-E39.

TQ-Systems GmbH recommends using the CINCON TRG70A power supply unit or equivalent, where PE is connected to GND.

1.9 ESD Considerations

To avoid damaging the MBox-R/-V/-VH-E39 caused by ESD make sure the following measures are adhered to:

Ground your workplace with e.g. anti-static mats and ground yourself with a wrist strap. Only use conductive tools when working on the MBox-R/-V/-VH-E39. Always handle electrostatic sensitive components at their edges, preferably wear conductive gloves. Remove the power cord from the MBox-R/-V/-VH-E39 before inserting or removing connectors or before inserting or removing add-on cards. Don't touch the contacts of connectors. Keep you work environment tidy and free of non-conductive materials.

1.10 Handling the MBox-R/-V/-VH-E39

Attention: Handling the MBox-R/-V/-VH-E39	
	<p>Improper or incorrect handling of the MBox-R/-V/-VH-E39 can substantially reduce its life span. TQ-Systems GmbH cannot be held responsible for unauthorized modifications made by the user and the consequences thereof, which may alter the conformity of the MBox-R/-V/-VH-E39.</p>

1.11 Coin Cell Battery

Attention: Coin cell battery	
	<p>Danger of explosion if the coin cell battery is incorrectly replaced. Replace the coin cell battery only with a coin cell battery of the same type and size. Check for correct polarity before inserting the coin cell battery in its socket. Do not immerse into water, heat to more than +100 °C, repair or disassemble the coin cell battery. Dispose the coin cell battery as required by local ordinances or regulations.</p>



2. ABOUT THIS MANUAL

2.1 Copyright and Licence Expenses

Copyright protected © 2021 by TQ-Systems GmbH.

This User's Guide may not be copied, reproduced, translated, changed or distributed, completely or partially in electronic, machine readable, or in any other form without the written consent of TQ-Systems GmbH.

The drivers and utilities for the components used as well as the BIOS are subject to the copyrights of the respective manufacturers. The licence conditions of the respective manufacturer are to be adhered to.

BIOS-licence expenses are paid by TQ-Systems GmbH and are included in the price.

Licence expenses for the operating system and applications are not taken into consideration and must be calculated / declared separately.

2.2 Registered Trademarks

TQ-Systems GmbH aims to adhere to copyrights of all graphics and texts used in all publications, and strives to use original or license-free graphics and texts.

All brand names and trademarks mentioned in the publication, including those protected by a third party, unless specified otherwise in writing, are subjected to the specifications of the current copyright laws and the proprietary laws of the present registered proprietor without any limitation. One should conclude that brand and trademarks are rightly protected by a third party.

2.3 Disclaimer

TQ-Systems GmbH does not guarantee that the information in this User's Guide is up-to-date, correct, complete or of good quality. Nor does TQ-Systems GmbH assume guarantee for further usage of the information.

Liability claims against TQ-Systems GmbH, referring to material or non-material related damages caused, due to usage or non-usage of the information given in the User's Guide, or due to usage of erroneous or incomplete information, are exempted, as long as there is no proven intentional or negligent fault of TQ-Systems GmbH. TQ-Systems GmbH explicitly reserves the rights to change or add to the contents of this User's Guide or parts of it without special notification.

2.4 Imprint

TQ-Systems GmbH

Gut Delling, Mühlstraße 2

D-82229 Seefeld

Tel: +49 8153 9308-0

Fax: +49 8153 9308-4223

Email: info@tq-group.com

Web: www.tq-group.com/

2.5 Service, Support, and RMA

Please visit our website www.tq-group.com for latest product documentation, drivers, utilities and technical support.

You can register on our website www.tq-group.com to have access to restricted information and automatic update services.

For direct technical support you can contact our FAE team support@tq-group.com.

Our FAE team can also support you with additional information, which is not provided on our website.

For service/RMA, please contact our service team service@tq-group.com or your TQ sales representative.



3. INTRODUCTION

The MBox-R/-V/-VH-E39 is a very compact Embedded PC based on Intel® Atom™ processor series E3900 (Apollo Lake) for embedded applications. The highly reliable hardware in combination with the rugged housing design enables the usage in industrial and harsh environmental conditions.

The MBox-R/-V/-VH-E39 focuses to meet individual configurations depending on customers demand. Functionality and interfaces can easily be added by internal Mini PCIe cards. Typical applications are embedded server and gateway applications, entry level PC systems for automation, visualisation and monitoring and all applications, which place high demands on quality, durability and long-term availability.

The name "MBox-R-E39" refers to the MBox with a "robust" housing. The "MBox-R" comes in one height with or without serial ports.

The name "MBox-V-E39" refers to the MBox with a "variable" housing. The "MBox-V" is available in two different heights, with serial ports (higher housing) or without serial ports (lower housing).

3.1 Functional Overview

The following key functions are implemented in the MBox-R/-V/-VH-E39:

External Interfaces (standard)

- 2 × Gigabit Ethernet
- 2 × USB 3.0
- 2 × Mini DisplayPort
- Power Button / Reset Button (rear)

Additional Interface according to the individual configuration

- 2 × D-Sub 9-pin (for i.e. RS-232 or other extension interfaces like fieldbus interfaces)
- 2 × SMA connector for antenna

Internal Interfaces and connection possibilities

- Mini PCIe socket (full size, with micro-SIM card support)
- Mini PCIe socket (half size)
- mSATA socket
- MicroSD card socket
- 2 × RS-232 (for internal use or available at the front)
- FAN connector
- Front panel connector

Power Supply

- Input voltage range: 9 to 30 V DC

3.2 MBox-R/-V/-VH-E39 Versions

Currently the MBox-R/-V/-VH-E39 is available in different configurations. The following table shows the details:

Table 2: MBox-R/-V/-VH-E39 Chassis Options



Table 3: MBox-R/-V/-VH-E39 Standard Versions

MBox	TQMxE39M	DDR3L SDRAM	Mass Storage	Power Consumption	Temp. Range
MBox-V-E3950-AA	TQMxE39M-AA	4 Gbyte	32 Gbyte eMMC	12 W (CPU)	-20 °C to +50 °C
MBox-R-E3950-AA	TQMxE39M-AA	4 Gbyte	32 Gbyte eMMC	12 W (CPU)	-20 °C to +50 °C

The MBox-R/-V/-VH-E39 focuses on individual / customer specific configurations and individual branding. For this reason several other TQMxE39M modules are available on request:

Table 4: TQMxE39M Module Versions

Module	CPU / Graphics	TPM	DDR3L SDRAM	eMMC	Temperature Module / System
TQMXE39M-AA	Intel Atom® x5-E3950 (4x 1.6/2.0GHz, 2MB Cache, 12 W TDP) Intel® HD Graphics 505 (18 EU, 500/650 MHz)	-	4 Gbyte	32 Gbyte	-40 °C to +85 °C / -20 °C to +50 °C
TQMXE39M-AC	Intel Atom® x5-E3930 (2x 1.3/1.8GHz, 2MB Cache, 6.5 W TDP) Intel® HD Graphics 500 (12 EU, 400/550 MHz)	-	2 Gbyte	-	0 °C to +60 °C / 0 °C to +50 °C
TQMXE39M-AH	Intel Atom® x5-E3950 (4x 1.6/2.0GHz, 2MB Cache, 12 W TDP) Intel® HD Graphics 505 (18 EU, 500/650 MHz)	-	8 Gbyte	32 Gbyte	-40 °C to +85 °C / -20 °C to +50 °C
TQMXE39M-AK	Intel Atom® x5-E3940 (4x 1.6/1.8GHz, 2MB Cache, 9 W TDP) Intel® HD Graphics 500 (12 EU, 400/600 MHz)	-	4 Gbyte	-	-40 °C to +85 °C / -20 °C to +60 °C

3.2 MBox-R/-V/-VH-E39 Versions (continued)

More configurations are possible:

Mass storage:

- 16 / 32 / 64 / 128 / 256 / 512 Gbyte mSATA (SATA III, MLC) (Standard-Temp. 0 °C to +70 °C)
- 32 / 64 / 128 / 256 / 512 Gbyte mSATA (SATA III, MLC) (Extended-Temp. –40 °C to +85 °C)
- Other mSATA flash drives on request

Add-ons:

- On request, e.g.:
 - WiFi (Extended-Temp: –40 °C to +85 °C), ZigBee, EnOcean
 - Fieldbus interfaces like CAN, ProfiNet, ProfiBus, DeviceNet, ModBus
 - Cellular connectivity (2G / 3G / LTE)

Note: Add-on cards



The device must be re-certified if add-on cards are installed.

4. FUNCTIONAL SPECIFICATION

4.1 Electrical Specification

4.1.1 Supply Voltage Characteristics

The MBox-R/-V/-VH-E39 supports a wide-range voltage input of 9 to 30 V DC.

Attention: Power requirement	
	Using a power adapter with Limited Power Source (LPS) certification IEC/EN62368-1 PS2 or IEC/EN60950-1 LPS (sub-clause 2.5) is compulsory.

TQ-Systems GmbH recommends the AC Adapter TRH70A120 from CINCON (Input 90 to 264 V AC) for applications **up to +45 °C**. A Power kit is available on request.

At higher ambient temperatures or other environmental conditions, a suitable power supply has to be chosen.

4.1.2 Power Consumption Specification

The power consumption of the system significantly depends on the configuration and the connected devices (COM Express™ module, mass storage devices, USB devices etc.). The maximum input current of the MBox-R/-V/-VH-E39 is limited to 5 A by a fuse. All USB devices connected to the MBox-R/-V/-VH-E39 should not exceed 5 W in total.

Note: Power requirement	
	The power supply for the MBox-R/-V/-VH-E39 must be configured with enough reserve. When selecting the power supply, the maximum power consumption of all components must be taken into account.

4.2 Environmental Specification

The following temperature parameters were determined by qualification tests (standard configurations without add-on cards, but with I-Temp mass storage):

- Storage temperature: –40 °C to +85 °C
- Operating temperature:
 - Depending on module and integrated add-on cards
 - 20 °C to +50 °C for high performance variants with extended temp.
 - 20 °C to +60 °C for low/mid performance variants with extended temp.
 - 0 °C to +60 °C for low/mid performance variants with standard temp.
- Relative humidity (operating / storage): 10 % to 90 % (not condensing)

When I/O extension modules or SSDs are selected, attention has to be paid to their storage and operating temperature limits. The temperature inside the MBox-R/-V/-VH-E39 differs from the ambient temperature. The modules should be specified for up to +85 °C. If modules with high power dissipation are used, the maximum operating temperature range for the device has to be verified.

Note: Environmental conditions	
	When powering the MBox-R/-V/-VH-E39, make sure the chassis is not covered by any objects. Otherwise the heat dissipation will be restricted by physical effects and the maximum operating temperature will be reduced.

4.3 Connectors and Interfaces

4.3.1 External Connectors and Interfaces Arrangement

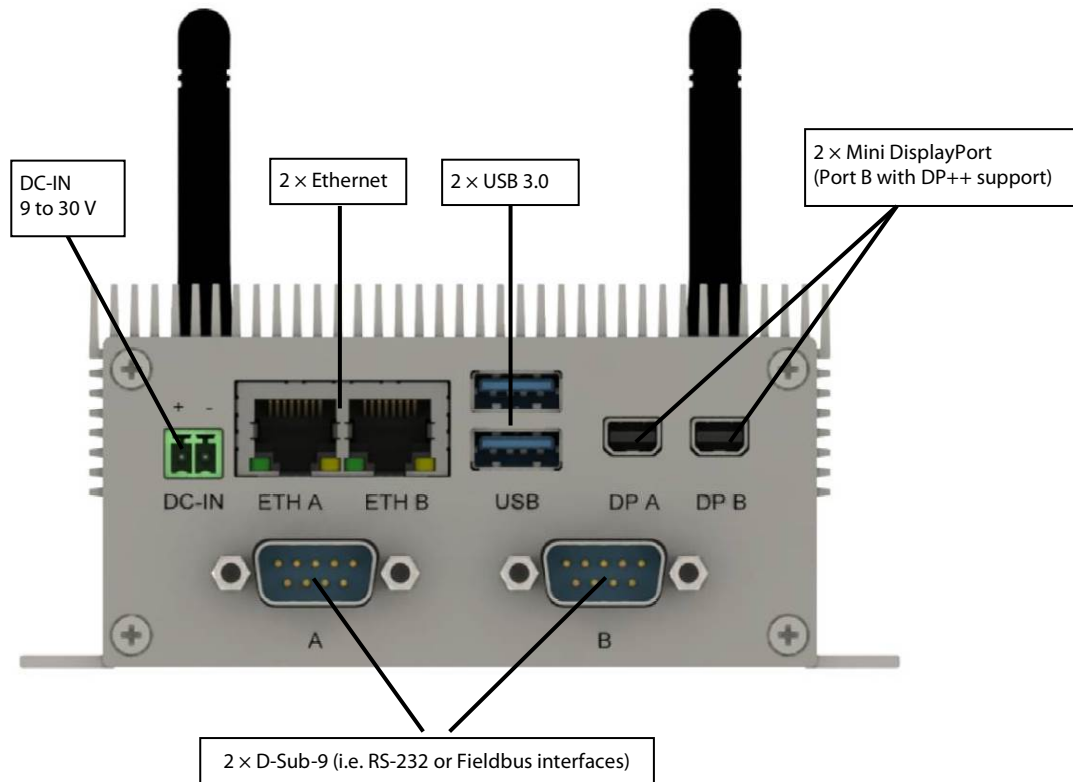

Figure 1: MBox-R-E39, Front with D-Sub-9 Connectors

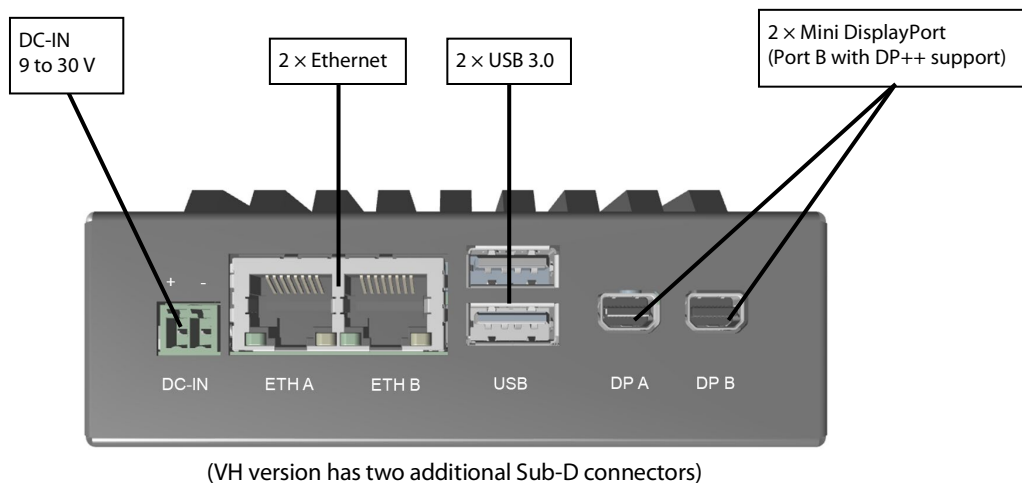
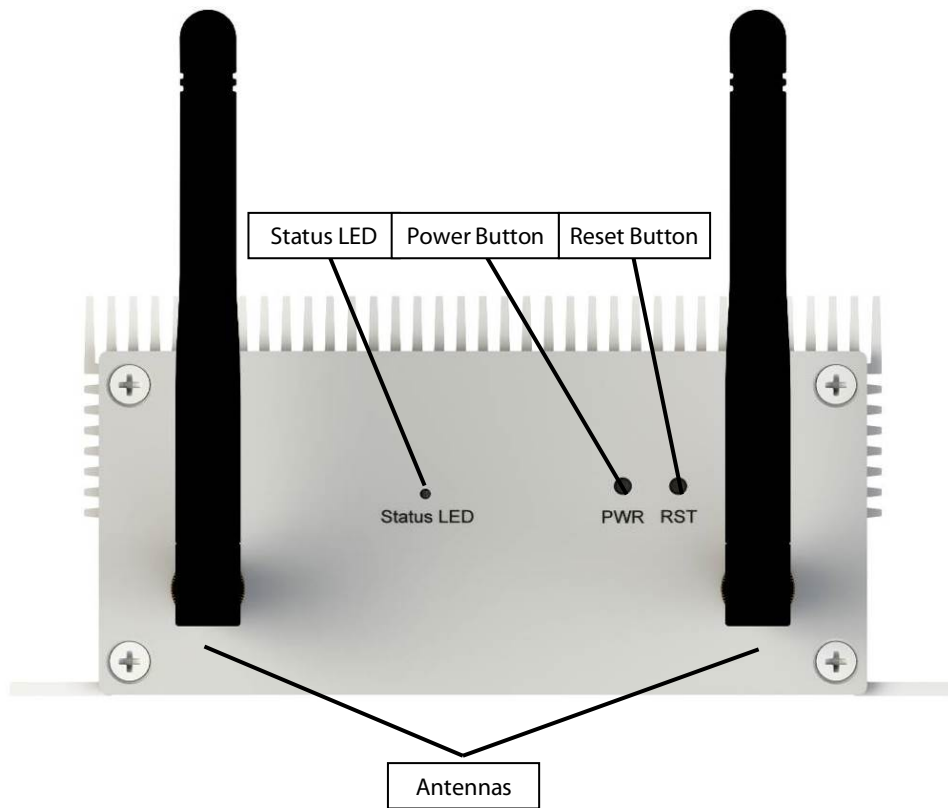

Figure 2: MBox-V-E39, Front without D-Sub-9 Connectors / MBox-VH-E39

4.3.1 External Connectors and Interfaces Arrangement (continued)



Holes for SMA-connectors are not supported in standard versions unless otherwise specified.

Figure 3: MBox-R-E39, Rear

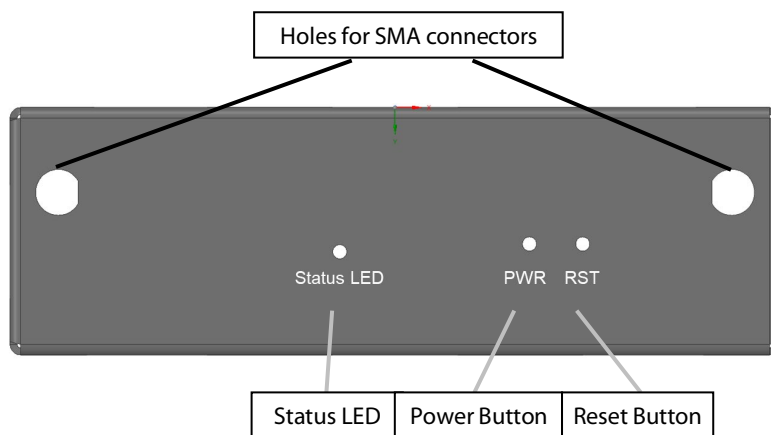

Figure 4: MBox-V-E39, Rear (also valid for MBox-VH-E39)

4.3.1.1 Power Supply Connector

The MBox-R/-V/-VH-E39 supports a wide-range voltage input from 9 to 30 V DC.

Power-In connector:

- Connector type: Phoenix MC1,5/2-G-3,5
- Mating connector: e.g. Phoenix FMC1,5/2-ST-3,5

Table 5: Pinout Power-In Connector

Pin	Signal	Remark
1 (+)	9 to 30 V	Fused @ 5 A
2 (-)	GND / chassis	-



Figure 5: DC Power Supply Connector

Note: Power requirement



Do not connect or disconnect the Power Supply to the MBox-R/-V/-VH-E39 under voltage. Switch off the voltage before plugging.

4.3.1.2 Mini DisplayPort

The MBox-R/-V/-VH-E39 supports two mini DisplayPort interfaces. The interfaces support DP++ signalling. Therefore it is possible to connect monitors with DP, DVI, HDMI and VGA input by using dedicated cables and adapters.

The actual configuration with the Intel Atom E3900 series has extended monitor support with resolutions up to 2 × 4K UHD. Port B supports DP++ with auto-detect of DP/HDMI.

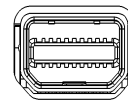

Figure 6: Mini DP Connector

4.3.1.3 USB Host Interfaces

The MBox-R/-V/-VH-E39 supports two USB Host interfaces.

Double A-Type USB connector for direct usage of USB host ports

- 2x USB 3.0

The maximum cable length of the USB interface is 3 m.

4.3.1.4 Gigabit Ethernet

The MBox-R/-V/-VH-E39 supports two standard Gigabit Ethernet ports.

An Intel® i210IT Ethernet controller with 10/100/1000 Mbps speed is implemented on both ports.

Table 6: Ethernet LEDs

LED	Colour / Status	Remark
Left (Link)	Off	No link
Left (Link)	Green	Link established
Right (ACT)	Off	No activity
Right (ACT)	Yellow	Activity



Figure 7: RJ45 Connectors



4.3.1.5 Status LED

The MBox-R/-V/-VH-E39 is equipped with a Status LED (on rear side).

Table 7: Status LED Conditions

Status LED	LED Colour	Description
Off	–	S5 State (System is shut down or not powered)
On	Green	S0 State (System is running)
On	Orange	S3 State (System is in Sleep mode)

4.3.1.6 Power Button and Reset Button

The Power Button and the Reset Button on the rear side of the MBox-R/-V/-VH-E39 provide the following functions.

Table 8: Power Button and Reset Button Functions

Status	Event	System response
No power supply connected	Supply with power	System starts automatically (S0)
System is shut down or in sleep mode (S3, S4, S5)	Push power button <5 sec	System starts (S0)
System is running (S0)	Push power button <5 sec	System shuts down or turns to sleep mode (S3, S4, S5), depending on Windows settings
System is running (S0)	Push power button >5 sec	Forced shutdown (S5)
System is running (S0)	Push reset button	Reset is generated

4.3.2 Optional External Connectors and Interfaces Arrangement

4.3.2.1 Serial Interfaces RS-232

The MBox-R/-V/-VH-E39 provides up to two serial ports:

- 2 × D-Sub-9 RS-232 port (4-wire)
- Legacy compatible (IO addresses and IRQs)
- Up to 115 kbaud

The interfaces are only supported in versions where they are explicitly specified in the configuration list.

To connect the internal RS-232 connectors to the front panel, the following adapters is used.

- Adapter cable 150 mm from internal connector to a 9-pin D-Sub connector, order code: 278622.0100



Figure 8: D-Sub-9 Adapter Cable

Table 9: RS-232 D-Sub-9 Connector

Pin	D-Sub-9 Connector
1	–
2	RXD
3	TXD
4	–
5	GND
6	–
7	RTS
8	CTS
9	–
10	–

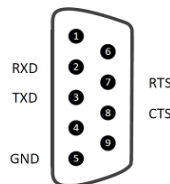

Figure 9: RS-232 D-Sub-9 Connector

If the D-Sub-9 connectors at the front are used for other interfaces (like Fieldbus), the RS-232 interfaces are not available.

4.3.2.2 SMA Antenna Connectors

In combination with a Wireless Mini PCI Express card, it is possible to add SMA antenna connectors for external antennas. For options and more information refer to chapter 3.2 and 4.3.2.5.

MBox-V-E39 and MBox-VH-E39 housings have the holes for SMA connectors as standard.

4.3.2.3 Other Optional Connectors

For individual solutions more optional connectors are available.

4.3.2.4 mSATA Interface for Mass Storage

An SSD can be plugged in the mSATA socket on the carrier board of the MBox-R/-V/-VH-E39.

The size can be chosen according the requirements. See “mass storage” in chapter 3.2.

4.3.2.5 Mini PCIe Extension Sockets

The MBox-R/-V/-VH-E39 provides up to two Mini PCIe card slots to extend the IOs or other system functionality.

One Mini PCIe slot also provides a micro-SIM card socket. The socket is accessible when the back panel is removed.

- One full-size socket (for 50.95 mm × 30 mm Mini PCIe cards)
 - Supports PCIe ×1 and USB 2.0
 - Micro-SIM card socket on carrier board in the MBox-R/-V/-VH-E39 (SIM/USIM card for 2G/3G/LTE modem support)
- One half-size socket (for 26.8 mm × 30 mm Mini PCIe cards)
 - Supports PCIe ×1 and USB 2.0

4.3.2.6 MicroSD Card Socket

The carrier board in the MBox-R/-V/-VH-E39 provides a microSD card socket. The socket is accessible when the back panel is removed.

5. MECHANICS

5.1 Dimensions

The following illustrations show the MBox-R-E39

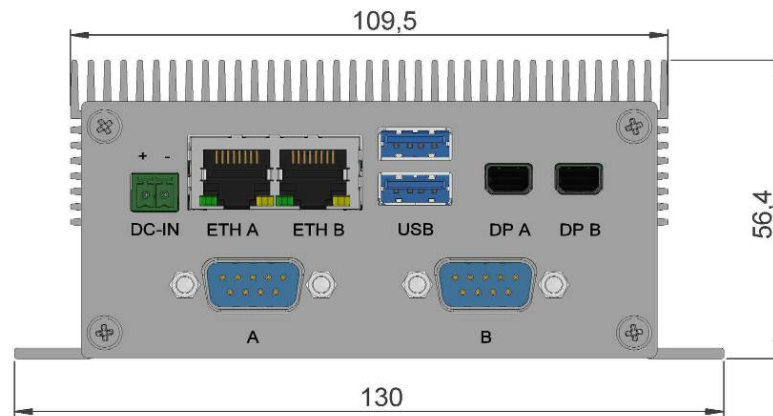

Figure 10: MBox-R-E39, Dimensions (mm), Front View

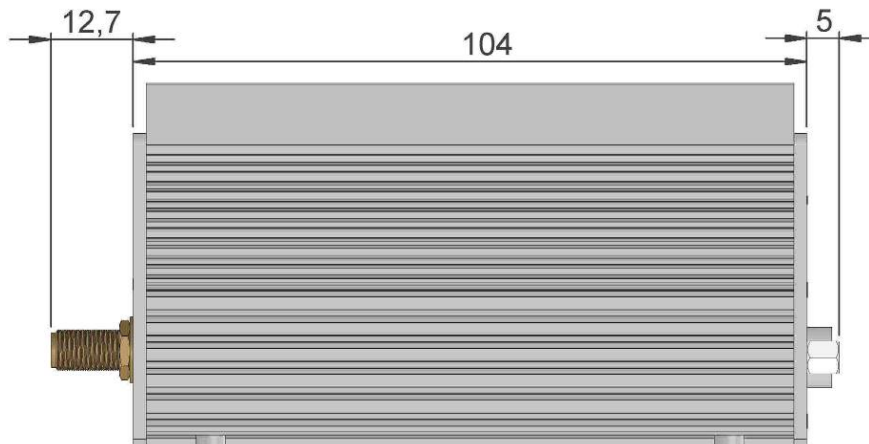

Figure 11: MBox-R-E39, Dimensions (mm), Side View

5.1 Dimensions (continued)

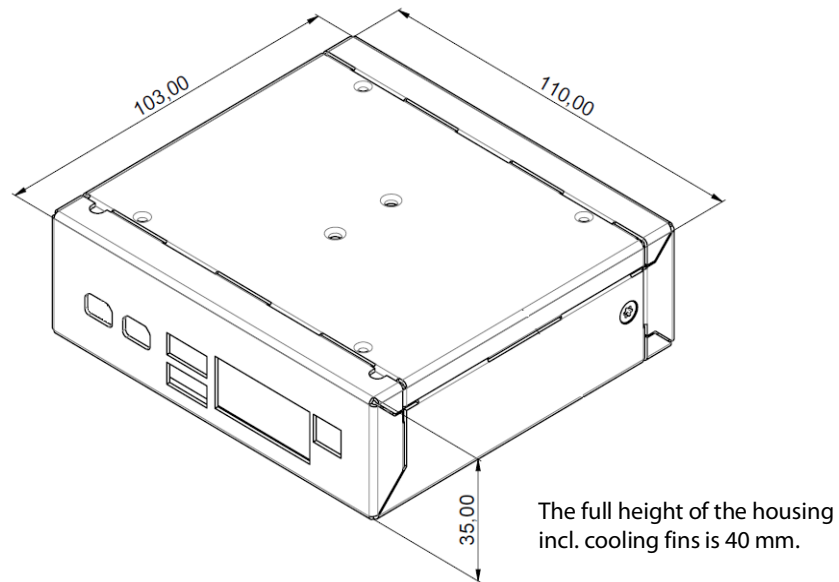

Figure 12: MBox-V-E39 (without D-Sub-9 Connectors), Dimensions (mm), Bottom View

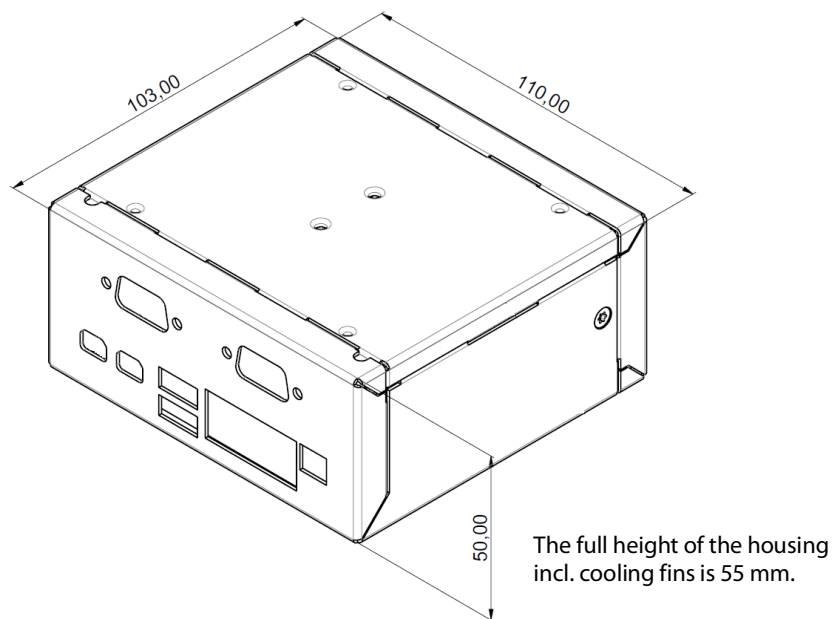

Figure 13: MBox-VH-E39 (with D-Sub-9 Connectors), Dimensions (mm), Bottom View

5.2 Mounting

There are several possibilities to mount the MBox-R/-V/-VH-E39:

- With an adapter plate
- To a DIN rail with an optional clamp (for MBox-V-E39 and MBox-VH-E39)
- Directly with screws

Please contact support@tq-group.com for more details or ideas suitable for your application.

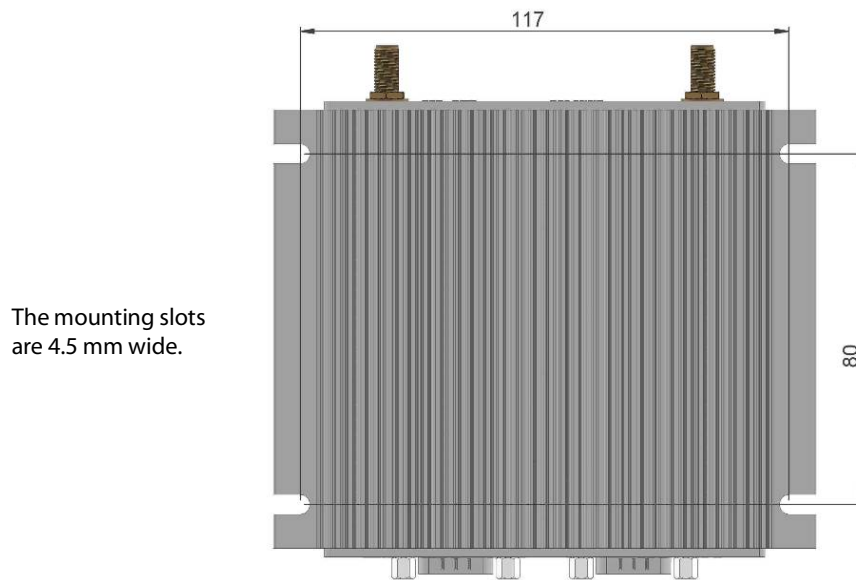

Figure 14: MBox-R-E39, Mounting Dimensions (mm), Top View

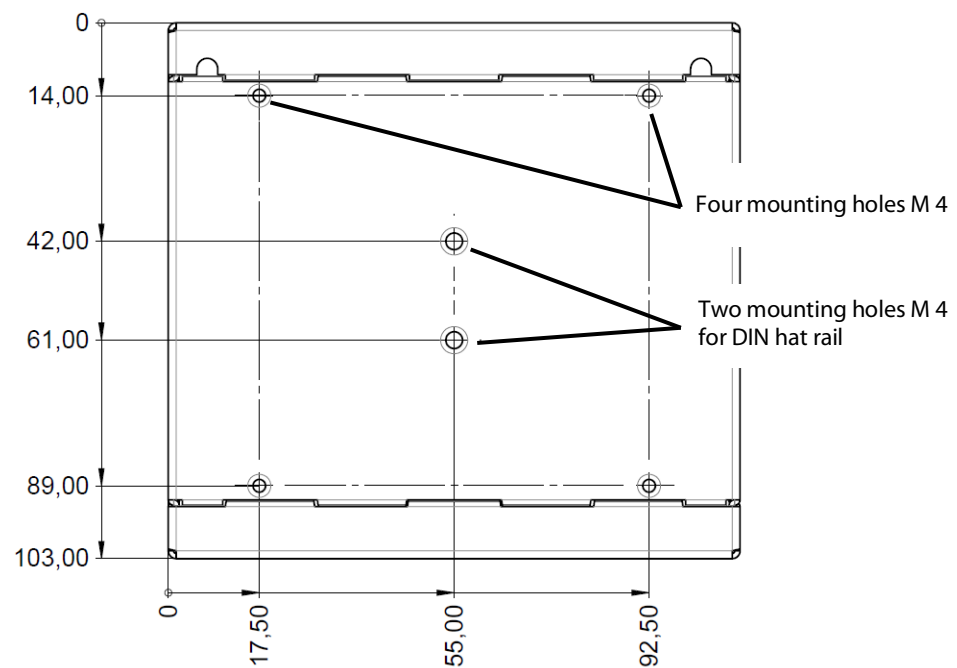

Figure 15: MBox-V-E39 / MBox-VH-E39, Dimensions of Mounting Holes (mm), Bottom View



6. REGULATORY INFORMATION

6.1 EU Compliance with Electromagnetic Compatibility Directive EC-Declaration of Conformity

We declare under our sole responsibility that the MBox-R/-V/-VH-E39 complies with the essential requirements which are laid down in the referred harmonization measures below:

- Directive 2011/65/EU combined with 2015/863/EU of the European Parliament on the restriction of the use of certain hazardous substances in electrical and electronic equipment
- Directive 2014/30/EU of the European Parliament on the harmonization of the laws of the Member States relating to electromagnetic compatibility.
- Directive 2012/19/EU of the European Parliament on waste electrical and electronic equipment (WEEE)

and complies with the appropriate harmonised standards or specifications:

- EN IEC 63000:2019, Technical documentation for the assessment of electrical and electronic products with respect to the restriction of hazardous substances
- EN 55032:2015, Electromagnetic compatibility of multimedia equipment - Emission Requirements class B.
- EN IEC 61000-6-2:2019, Electromagnetic compatibility – immunity for industrial environments
- IEC 62368-1:2018, Audio/video, information and communication technology equipment – Part 1: Safety requirements

7. WEEE AND RECYCLING

7.1 WEEE

TQ-Systems GmbH encourages owners to recycle their MBox-R/-V/-VH-E39 when it is not used anymore.

The Waste Electrical and Electronic Equipment (WEEE) mark only applies to countries within the European Union (EU) and Norway. Appliances are labelled in accordance with European Directive 2012/19/EU concerning waste electrical and electronic equipment (WEEE). The Directive determines the framework for the return and recycling of used appliances as applicable throughout the European Union.

7.2 Recycling

Users of the MBox-R/-V/-VH-E39 must not dispose the MBox-R/-V/-VH-E39 as unsorted municipal waste, but use the collection framework available in their country for the return, recycle, or recovery of WEEE and minimize any potential effects on the environment and human health due to the presence of hazardous substances.



8. APPENDIX

8.1 Driver Download

The MBox-R/-V/-VH-E39 is well supported by Standard Operating Systems, which already include most of the drivers required. Use the latest Intel® drivers to optimize performance and make use of the full MBox-R/-V/-VH-E39 feature set.

Please visit the TQ product webpage for detailed information, where drivers can be downloaded.

<https://www.tq-group.com/en/products/tq-embedded/x86-architecture/tqmx39m/>

