

EM420 with Sensorbars

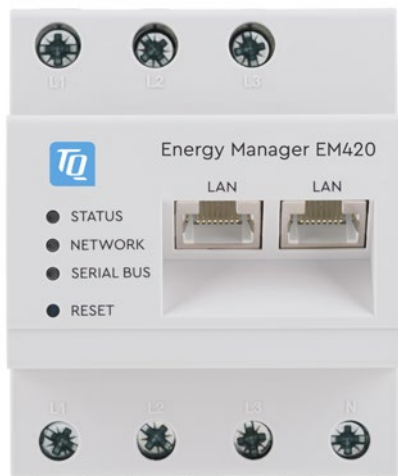

The perfect combination for recording and understanding energy data. With European patent.



EM420

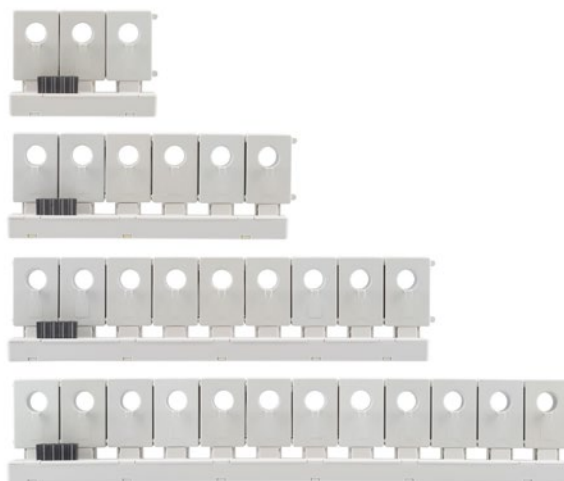

Sensorbars with current sensors

EM420 – The Energy Manager for precise and continuous monitoring of energy flows in industrial, commercial and residential properties. The perfect foundation for reliable analyses.

EM420 PERFORMANCE FEATURES:

- ▶ Continuous storage of data for long-term analysis
- ▶ Long-term data storage configurable down to 1 second intervals
- ▶ Event-triggered recording of measured data down to 200 ms intervals with pre-trigger and post-trigger time
- ▶ Recording of starting currents and voltage dips or spikes
- ▶ Measured data output as CSV files via FTP/SFTP or email
- ▶ Standard communication interfaces Modbus TCP / RTU (master/slave) and web interface (HTTPS in JSON format)
- ▶ 200 ms data communication possible via Modbus (master and slave)
- ▶ Modbus register to OBIS standard and Sunspec
- ▶ Data can be easily incorporated into IoT platforms via MQTT (smallest resolution 1 second)
- ▶ Device is easy to configure via integrated web server
- ▶ Plug & Play set-up
- ▶ Easy access in the network via UPnP
- ▶ Visualisation of energy flows in Sankey format

- ▶ Extension of the energy analysis for equipment or production stations via the TQ sensors (up to 63 A)
- ▶ Energy balance made available at the building connection point for demand-controlled automation of consumers and generators with the DM100

EM420 KEY FUNCTIONS:

- ▶ Fully-integrated smart meter *
- ▶ High measurement accuracy
- ▶ Real-time data acquisition
- ▶ Four-quadrant meter
- ▶ 3-phase energy measurement for consumption and feed-in
- ▶ Direct connection up to 63 A or from 100 A up to 1000 A via external instrument transformer
- ▶ Option of connecting up to 96 further current sensors for detailed monitoring of the sub-distribution board/at the circuit level
- ▶ Decentralised data archive with capacity for up to 15 years
- ▶ Mounted on DIN rail (4 DIN units)

* Not approved for generating billing data

TECHNICAL DATA FOR THE EM420

PROCESSOR UNIT

Processor	450 MHz ARM9 processor
RAM	256 MB
Flash memory	4 GB eMMC (1.1 GB for permanent data retention)
Operating system	Embedded Linux with integrated TCP/IP stack
Interfaces (standard)	2 x LAN (10/100 Mbit) 2 x RS485 (half-duplex, max. 115200 baud)

PRODUCT SAFETY

Product standards	EN 61010-1, EN 61010-2-030 EN 61010-2-201
--------------------------	----------------------------------------------

ELECTROMAGNETIC COMPATIBILITY

Product standards	EN 61326-1, table 2 (industry)
--------------------------	--------------------------------

Interference immunity

ESD (IEC 61000-4-2)	4 kV contact discharge 8 kV air discharge
RF radiation (IEC 61000-4-3)	3 V/m 10 V/m for increased deviation in measuring accuracy
Burst (IEC 61000-4-4)	Grid: 4 kV Ethernet: 2 kV
Surge (IEC 61000-4-5)	L-L: 1 kV, L-N: 2 kV Ethernet: 1 kV
Conducted disturbances (IEC 61000-4-6)	150 kHz ... 80 MHz, 10 V (RMS value)
Magnetic field (IEC 61000-4-8)	30 A/m
Voltage dips (IEC 61000-4-11)	100 %, 20 ms (remains active) 60 %, 200 ms (active / restart) 30 %, 500 ms (active / restart) 100%, 5 s (restart)

Radiated interference

Disturbance voltage (EN 55011)	Grid, class B
Disturbance current (EN 55011)	Ethernet, class B
Electromagnetic interference (EN 55011)	30 MHz ... 1 GHz, class B
Harmonics (EN 61000-3-2)	Grid, class A
Voltage fluctuations (EN 61000-3-3)	Grid

POWER SUPPLY

Overvoltage category	300 V CAT III
Supply voltage	L1/N: 110 V AC / 230 V AC ± 10 %
Frequency	50 / 60 Hz ± 5 %
Power consumption P_{max}	5.0 W

VOLTAGE AND CURRENT INPUTS

Overvoltage category	300 V CAT III
Rated voltage	max. 230 / 400 V AC
Limit current I_N / phase	63 A
Frequency	50/60 Hz ± 5 %

CONNECTION

Connection cross section in line with EN 60204	10–25 mm ²
Connection cross section, mech.	1.5–25 mm ²

Tightening torque for screw terminals	2.0 Nm
----------------------------------------------	--------

MECHANICAL DATA

Housing material	Glass fibre-reinforced polyamide
Fire-resistance	UL94-V0
Protection class	II
Degree of protection	IP2X
Weight	0.3 kg
Dimensions	88×70×65 mm
Width	4 DIN units

AMBIENT CONDITIONS

Ambient temperature in operation	-25 ... 45 °C or -25 ... 55 °C with reduced I_N at 32 A *1
Ambient temperature during transportation / storage	-25 ... 70 °C
Relative humidity (non-condensing)	Up to 75 % as an annual average, up to 95 % on up to 30 days/year
Max. altitude	2000 m above sea level

*1 The constraints as described in the installation instructions apply to operation at ambient temperatures up to 55 °C

MEASUREMENT ACCURACY

Measured variable	Typical full-scale accuracy
Phase current	± 0.2 %
Voltage	± 0.2 %
Total active power	± 0.5 %
Total reactive power	± 0.5 %
Frequency	± 0.1 %
Power factor	± 0.5 %

Measured variable	Accuracy class
Total active energy	1 IEC 62053-21
Total reactive energy	1 IEC 62053-23

The available measuring accuracy is to be taken into account when using external current transformers.

SENSORBARS

PERFORMANCE FEATURES

- ▶ The Sensorbar is used to measure currents of up to 63 A in AC mains networks.
- ▶ This allows the output to be measured and details of the active energy of individual consumers to be recorded in low voltage networks. The voltage measured in the Energy Manager and the power factor per phase are used to calculate the active power.
- ▶ The measured data is sent via the RS485 bus to the Energy Manager, where it is analysed. The Sensorbar is powered via the Energy Manager. There are four versions of the Sensorbar available – with three (EB203), six (EB206), nine (EB209) or twelve (EB212) slots for the current sensors. The current sensors are seated directly on the circuit breakers and measure the associated phase current.
- ▶ Up to eight Sensorbars can be connected to an Energy Manager unit. Sensorbar EB212 with twelve current sensors can be used to measure the currents from up to 96 conductors and send them to the Energy Manager.

KEY FUNCTIONS

- ▶ Energy monitoring extended to the circuit level
- ▶ Up to 96 current sensors can be connected to one Energy Manager unit
- ▶ Groups of consumers can be interconnected and monitored
- ▶ Easy, space-saving installation via circuit breakers, easy retrofitting
- ▶ No further power supply unit needed to supply the current sensors

TECHNICAL DATA FOR SENSORBARS

RS485 INTERFACE INCLUDING POWER SUPPLY

Supply voltage	9 V DC ±10 %
Power consumption P_{max}	0.5 W
Max. line length	10 m
Protocol	Modbus RTU, baud rate 38400, 8N1
Terminations integrated	No

EC 63 CURRENT TRANSFORMER

Overvoltage category	300 V CAT III
Working voltage rated value	250 V AC
Current rated value	63 A
Frequency	50/60 Hz ±5 %
Opening	7.8 mm

MECHANICAL DATA

Housing material	Glass fibre-reinforced polyamide
Fire-resistance	UL94-V0
Degree of protection	IP2X
Dimensions (L x W x D) / weight	EB203 56×25×40 mm / approx. 26 g EB206 108×25×40 mm / approx. 34 g EB209 161×25×40 mm / approx. 42 g EB212 213×25×40 mm / approx. 50 g

CONNECTION

Fieldbus connection cross section	0.25 mm ² to 1.5 mm ²
Power cable connection cross section as per DIN 57100 part 523/ VDE 0100 part 523.6–81	1.5 mm ² to 10 mm ²

AMBIENT CONDITIONS

Ambient temperature in operation	-25 ... 55 °C
Ambient temperature during transportation / storage	-25 ... 70 °C
Relative humidity (non-condensing)	50 ... 95 %
Max. altitude	2000 m above sea level

PRODUCT SAFETY

Product standards	EN 61010-1 EN 61010-2-030
--------------------------	------------------------------

ELECTROMAGNETIC COMPATIBILITY

Product standards	EN 61326-1, table 2 (industry) EN 61000-6-3 EN 61000-6-2
--------------------------	----------------------------------------------------------------

MEASUREMENT ACCURACY

Measurement accuracy *1	±1 %
--------------------------------	------

*1 Full-scale, fundamental frequency only

TYPICAL APPLICATION IN INDUSTRY

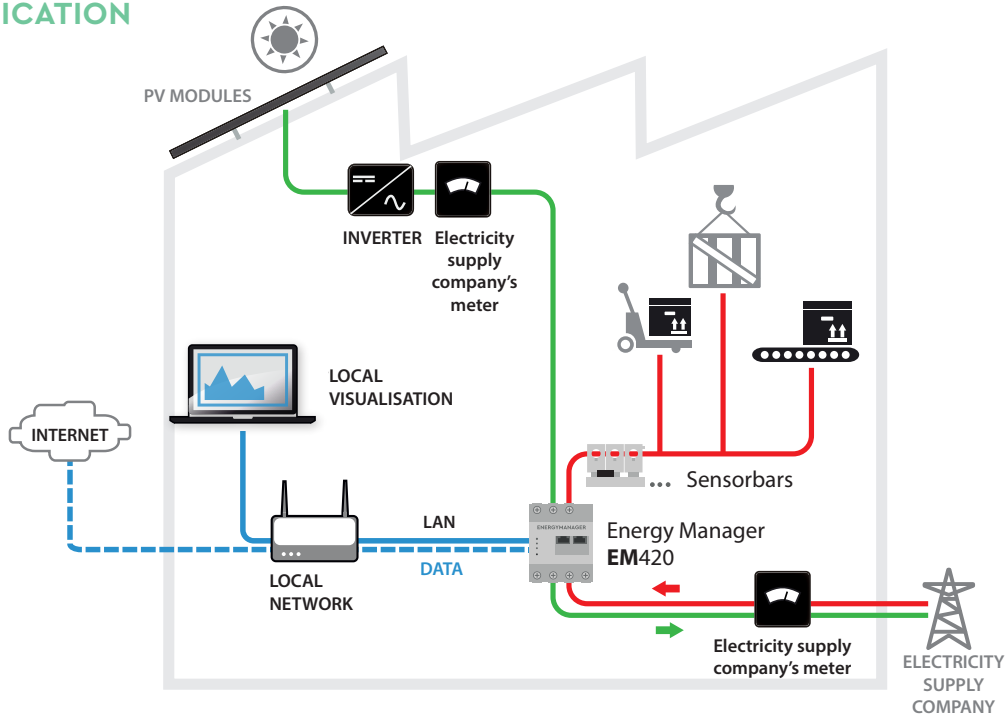

CONNECTION DIAGRAM

Figure: Connection for indirect measurement with current transformers

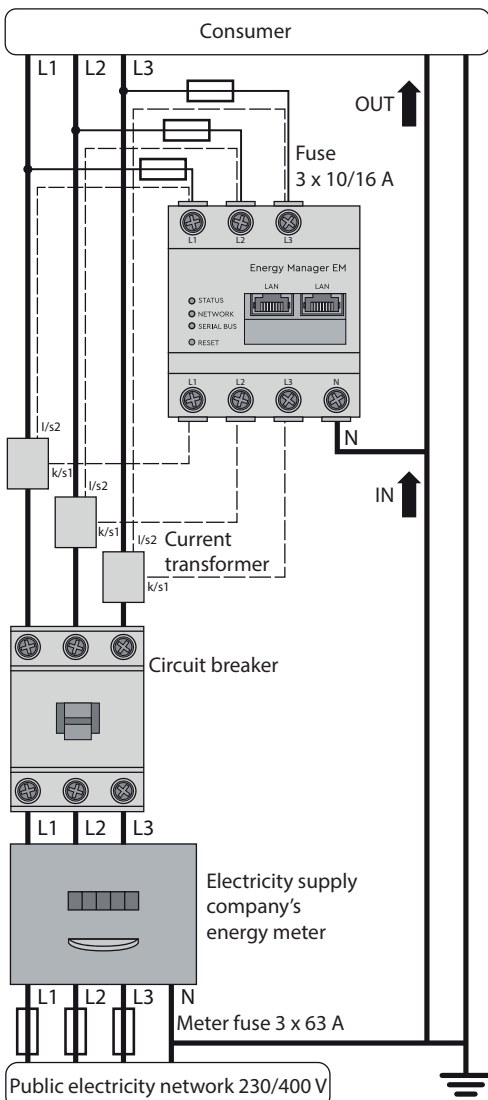
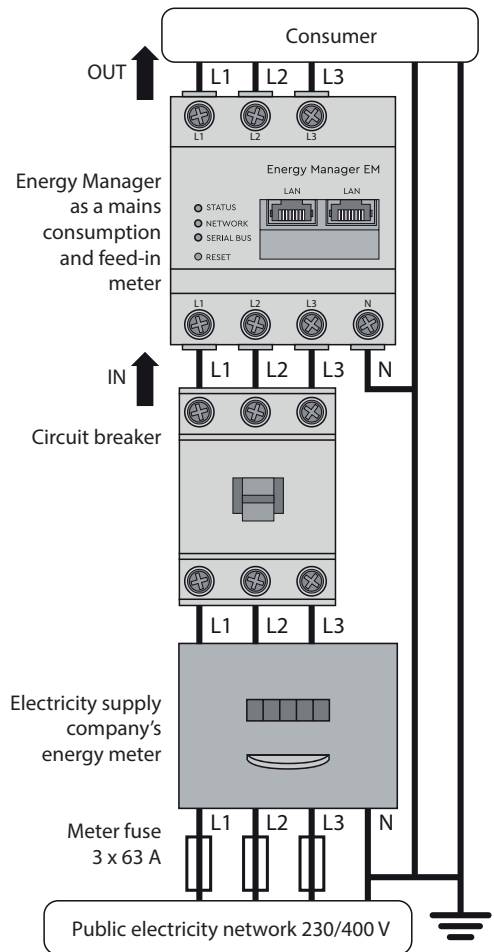

Figure: Connection for direct measurement



TQ-Systems GmbH

Mühlstraße 2 | Gut Delling | 82229 Seefeld | Germany
Phone: +49 8153 9308-655 | info@tq-automation.com

tq-automation.com